

# Always the right Fuse-Link

**NH Fuse-Link 400 V  
with twin indicator**



**NH Fuse-Links  
for special industrial  
applications, e.g. mining industry**



**gTr Fuse-Links  
for transformer protection**



**NH Fuse-Links  
up to 1500 V AC**



# Content

NH Fuse-Links AC 400 V gG	<b>20</b>	<b>Z</b>
NH Fuse-Links AC 500 V gG	<b>23</b>	
NH Fuse-Links AC 500 V gL	<b>27</b>	
NH Fuse-Links AC 690 V gG	<b>31</b>	
NH Fuse-Links AC 400 V gTr	<b>33</b>	
NH Fuse-Links AC 500 V gR	<b>34</b>	
NH Fuse-Links AC 1000 V gB/aM	<b>37</b>	
NH Fuse-Links AC 1000/1500 V TF	<b>38</b>	
Technical Data	<b>see page 40</b>	



## System

Developed out of its traditional competence, EFEN offers a complete system of NH Fuse-Links according to the newest state of technology. Today, EFEN NH Fuse-Links belong to the leading products on the market. A high technical standard continuously ensures an excellent quality. Particularly remarkable for the EFEN-assortment is the diversity of its special applications.

## Features

EFEN NH Fuse-Links comply with national and inter-national standards such as DIN, VDE and IEC. The Fuse-Links are available with death metal and live metal gripping lugs. A wide assortment of accessories completes this product-range.

**gR NH Fuse-Links for the protection of semiconductors**



**Special Fuse-Links for DC applications (see page 314 ff.)**



## NH Fuse-Links 400 V gG

**Rated voltage: AC 400 V**

Utilization category: gG acc.  
VDE 0636-2 + VDE 0636-1

IEC 60269-2 + IEC 60269-1  
Breaking capacity 100 kA



35404-1600

### NH Fuse-Links for cable and line protection, AC 400 V gG

**Properties:**

- Twin indicator (size 3, 500 A and 630 A with middle indicator)
- Live metal gripping lugs
- Fuse element copper

Description	Size	Amps	Order-No.	PU	PG	Sur. Ag	Sur. Cu	Price €/pc.
NH-SI 000 2A GG AC400V AK	000	2	<b>35401-0020</b>	3	N 5	0,001	0,003	4,05
NH-SI 000 4A GG AC400V AK	000	4	<b>35401-0040</b>	3	N 5	0,001	0,003	4,05
NH-SI 000 6A GG AC400V AK	000	6	<b>35401-0060</b>	3	N 5	0,001	0,003	3,30
NH-SI 000 10A GG AC400V AK	000	10	<b>35401-0100</b>	3	N 5	0,001	0,003	3,30
NH-SI 000 16A GG AC400V AK	000	16	<b>35401-0160</b>	9	N 5	0,001	0,003	3,30
NH-SI 000 20A GG AC400V AK	000	20	<b>35401-0200</b>	9	N 5	0,001	0,003	3,30
NH-SI 000 25A GG AC400V AK	000	25	<b>35401-0250</b>	9	N 5	0,001	0,003	3,30
NH-SI 000 32A GG AC400V AK	000	32	<b>35401-0320</b>	9	N 5	0,001	0,003	3,30
NH-SI 000 35A GG AC400V AK	000	35	<b>35401-0350</b>	9	N 5	0,001	0,003	3,30
NH-SI 000 40A GG AC400V AK	000	40	<b>35401-0400</b>	9	N 5	0,001	0,003	3,30
NH-SI 000 50A GG AC400V AK	000	50	<b>35401-0500</b>	9	N 5	0,001	0,003	3,30
NH-SI 000 63A GG AC400V AK	000	63	<b>35401-0630</b>	9	N 5	0,001	0,003	3,30
NH-SI 000 80A GG AC400V AK	000	80	<b>35401-0800</b>	9	N 5	0,001	0,003	3,30
NH-SI 000 100A GG AC400V AK	000	100	<b>35401-1000</b>	9	N 5	0,001	0,003	3,30
NH-SI 00 63A GG AC400V AK	00	63	<b>35402-0630</b>	3	N 5	0,002	0,004	3,50
NH-SI 00 80A GG AC400V AK	00	80	<b>35402-0800</b>	3	N 5	0,002	0,004	3,50
NH-SI 00 100A GG AC400V AK	00	100	<b>35402-1000</b>	3	N 5	0,002	0,004	3,50
NH-SI 00 125A GG AC400V AK	00	125	<b>35402-1250</b>	3	N 5	0,002	0,004	3,75
NH-SI 00 160A GG AC400V AK	00	160	<b>35402-1600</b>	3	N 5	0,002	0,007	3,85
NH-SI 1/16A GG AC400V AK	1	16	<b>35403-0160</b>	3	N 5	0,003	0,008	7,75
NH-SI 1/20A GG AC400V AK	1	20	<b>35403-0200</b>	3	N 5	0,003	0,009	7,75
NH-SI 1/25A GG AC400V AK	1	25	<b>35403-0250</b>	3	N 5	0,003	0,010	7,75
NH-SI 1/32A GG AC400V AK	1	32	<b>35403-0320</b>	3	N 5	0,003	0,010	7,75
NH-SI 1/35A GG AC400V AK	1	35	<b>35403-0350</b>	3	N 5	0,003	0,010	7,75
NH-SI 1/40A GG AC400V AK	1	40	<b>35403-0400</b>	3	N 5	0,003	0,010	7,75
NH-SI 1/50A GG AC400V AK	1	50	<b>35403-0500</b>	3	N 5	0,003	0,010	7,75
NH-SI 1/63A GG AC400V AK	1	63	<b>35403-0630</b>	3	N 5	0,003	0,010	7,75
NH-SI 1/80A GG AC400V AK	1	80	<b>35403-0800</b>	3	N 5	0,003	0,010	7,75
NH-SI 1/100A GG AC400V AK	1	100	<b>35403-1000</b>	3	N 5	0,003	0,010	7,75
NH-SI 1 125A GG AC400V AK	1	125	<b>35403-1250</b>	3	N 5	0,003	0,010	7,75
NH-SI 1 160A GG AC400V AK	1	160	<b>35403-1600</b>	3	N 5	0,003	0,010	7,75
NH-SI 1 200A GG AC400V AK	1	200	<b>35403-2000</b>	3	N 5	0,003	0,010	9,90
NH-SI 1 224A GG AC400V AK	1	224	<b>35403-2240</b>	3	N 5	0,003	0,010	9,90
NH-SI 1 250A GG AC400V AK	1	250	<b>35403-2500</b>	3	N 5	0,003	0,010	9,90
NH-SI 2/35A GG AC400V AK	2	35	<b>35404-0350</b>	3	N 5	0,004	0,019	11,10
NH-SI 2/50A GG AC400V AK	2	50	<b>35404-0500</b>	3	N 5	0,004	0,019	11,10
NH-SI 2/63A GG AC400V AK	2	63	<b>35404-0630</b>	3	N 5	0,004	0,019	11,10
NH-SI 2/80A GG AC400V AK	2	80	<b>35404-0800</b>	3	N 5	0,004	0,019	11,10
NH-SI 2/100A GG AC400V AK	2	100	<b>35404-1000</b>	3	N 5	0,004	0,019	11,10
NH-SI 2/125A GG AC400V AK	2	125	<b>35404-1250</b>	3	N 5	0,004	0,019	11,10
NH-SI 2/160A GG AC400V AK	2	160	<b>35404-1600</b>	3	N 5	0,004	0,019	11,10
NH-SI 2/200A GG AC400V AK	2	200	<b>35404-2000</b>	3	N 5	0,004	0,019	13,20
NH-SI 2/224A GG AC400V AK	2	224	<b>35404-2240</b>	3	N 5	0,004	0,019	13,20
NH-SI 2/250A GG AC400V AK	2	250	<b>35404-2500</b>	3	N 5	0,004	0,019	13,20
NH-SI 2 300A GG AC400V AK	2	300	<b>35404-3000</b>	3	N 5	0,004	0,019	13,20
NH-SI 2 315A GG AC400V AK	2	315	<b>35404-3150</b>	3	N 5	0,004	0,019	19,50
NH-SI 2 355A GG AC400V AK	2	355	<b>35404-3550</b>	3	N 5	0,004	0,019	19,50
NH-SI 2 400A GG AC400V AK	2	400	<b>35404-4000</b>	3	N 5	0,004	0,019	19,50
NH-SI 3/250A GG AC400V AK	3	250	<b>35405-2500</b>	1	N 5	0,007	0,024	19,80
NH-SI 3/300A GG AC400V AK	3	300	<b>35405-3000</b>	1	N 5	0,007	0,026	19,80
NH-SI 3/315A GG AC400V AK	3	315	<b>35405-3150</b>	1	N 5	0,007	0,026	19,80
NH-SI 3/400A GG AC400V AK	3	400	<b>35405-4000</b>	1	N 5	0,007	0,026	19,80
NH-SI 3/425A GG AC400V AK	3	425	<b>35405-4250</b>	1	N 5	0,007	0,026	19,80
NH-SI 3 500A GG AC400V MA	3	500	<b>35405-5000</b>	1	N 5	0,007	0,026	22,05
NH-SI 3 630A GG AC400V MA	3	630	<b>35405-6300</b>	1	N 5	0,007	0,026	37,20

## NH Fuse-Links 400 V gG

**Rated voltage: AC 400 V**  
 Utilization category: gG acc.  
 VDE 0636-2 + VDE 0636-1  
 IEC 60269-2 + IEC 60269-1  
 Breaking capacity 100 kA

Z



35407-1600

### NH Fuse-Links for cable and line protection, AC 400 V gG

**Properties:**

- Twin indicator
- dead metal gripping lugs
- Fuse element copper

Description	Size	Amps	Order-No.	PU	PG	Sur. Ag	Sur. Cu	Price €/pc.
NH-SI 000 2A GG AC400V LI AK	000	2	<b>35406-0020</b>	3	N 5	0,001	0,003	4,15
NH-SI 000 4A GG AC400V LI AK	000	4	<b>35406-0040</b>	3	N 5	0,001	0,003	4,15
NH-SI 000 6A GG AC400V LI AK	000	6	<b>35406-0060</b>	3	N 5	0,001	0,003	4,15
NH-SI 000 10A GG AC400V LI AK	000	10	<b>35406-0100</b>	3	N 5	0,001	0,003	4,15
NH-SI 000 16A GG AC400V LI AK	000	16	<b>35406-0160</b>	9	N 5	0,001	0,003	4,15
NH-SI 000 20A GG AC400V LI AK	000	20	<b>35406-0200</b>	9	N 5	0,001	0,003	4,15
NH-SI 000 25A GG AC400V LI AK	000	25	<b>35406-0250</b>	9	N 5	0,001	0,003	4,15
NH-SI 000 32A GG AC400V LI AK	000	32	<b>35406-0320</b>	9	N 5	0,001	0,003	4,15
NH-SI 000 35A GG AC400V LI AK	000	35	<b>35406-0350</b>	9	N 5	0,001	0,003	4,15
NH-SI 000 40A GG AC400V LI AK	000	40	<b>35406-0400</b>	9	N 5	0,001	0,003	4,15
NH-SI 000 50A GG AC400V LI AK	000	50	<b>35406-0500</b>	9	N 5	0,001	0,003	4,15
NH-SI 000 63A GG AC400V LI AK	000	63	<b>35406-0630</b>	9	N 5	0,001	0,003	4,15
NH-SI 000 80A GG AC400V LI AK	000	80	<b>35406-0800</b>	9	N 5	0,001	0,003	4,15
NH-SI 000 100A GG AC400V LI AK	000	100	<b>35406-1000</b>	9	N 5	0,001	0,003	4,15
NH-SI 00 63A GG AC400V LI AK	00	63	<b>35407-0630</b>	3	N 5	0,002	0,004	4,35
NH-SI 00 80A GG AC400V LI AK	00	80	<b>35407-0800</b>	3	N 5	0,002	0,004	4,35
NH-SI 00 100A GG AC400V LI AK	00	100	<b>35407-1000</b>	3	N 5	0,002	0,004	4,35
NH-SI 00 125A GG AC400V LI AK	00	125	<b>35407-1250</b>	3	N 5	0,002	0,004	4,35
NH-SI 00 160A GG AC400V LI AK	00	160	<b>35407-1600</b>	3	N 5	0,002	0,007	4,35
NH-SI 1/ 16A GG AC400V LI AK	1	16	<b>35408-0160</b>	3	N 5	0,003	0,008	11,10
NH-SI 1/ 20A GG AC400V LI AK	1	20	<b>35408-0200</b>	3	N 5	0,003	0,009	11,10
NH-SI 1/ 25A GG AC400V LI AK	1	25	<b>35408-0250</b>	3	N 5	0,003	0,010	11,10
NH-SI 1/ 32A GG AC400V LI AK	1	32	<b>35408-0320</b>	3	N 5	0,003	0,010	11,10
NH-SI 1/ 35A GG AC400V LI AK	1	35	<b>35408-0350</b>	3	N 5	0,003	0,010	11,10
NH-SI 1/ 40A GG AC400V LI AK	1	40	<b>35408-0400</b>	3	N 5	0,003	0,010	11,10
NH-SI 1/ 50A GG AC400V LI AK	1	50	<b>35408-0500</b>	3	N 5	0,003	0,010	11,10
NH-SI 1/ 63A GG AC400V LI AK	1	63	<b>35408-0630</b>	3	N 5	0,003	0,010	11,10
NH-SI 1/ 80A GG AC400V LI AK	1	80	<b>35408-0800</b>	3	N 5	0,003	0,010	11,10
NH-SI 1/ 100A GG AC400V LI AK	1	100	<b>35408-1000</b>	3	N 5	0,003	0,010	11,10
NH-SI 1 125A GG AC400V LI AK	1	125	<b>35408-1250</b>	3	N 5	0,003	0,010	11,10
NH-SI 1 160A GG AC400V LI AK	1	160	<b>35408-1600</b>	3	N 5	0,003	0,010	11,55
NH-SI 1 200A GG AC400V LI AK	1	200	<b>35408-2000</b>	3	N 5	0,003	0,010	12,10
NH-SI 1 224A GG AC400V LI AK	1	224	<b>35408-2240</b>	3	N 5	0,003	0,010	12,10
NH-SI 1 250A GG AC400V LI AK	1	250	<b>35408-2500</b>	3	N 5	0,003	0,010	12,10

## NH Fuse-Links 400 V gG

**Rated voltage: AC 400 V**

Utilization category: gG acc.

VDE 0636-2 + VDE 0636-1

IEC 60269-2 + IEC 60269-1

Breaking capacity 100 kA



35407-1600

**NH Fuse-Links for cable and line protection, AC 400 V gG**
**Properties:**

- Twin indicator (size 3, 500 A and 630 A with middle indicator)
- dead metal gripping lugs
- Fuse element copper

Description	Size	Amps	Order-No.	PU	PG	Sur. Ag	Sur. Cu	Price €/pc.
NH-SI 2/ 35A GG AC400V LI AK	2	35	<b>35409-0350</b>	3	N 5	0,004	0,019	14,35
NH-SI 2/ 50A GG AC400V LI AK	2	50	<b>35409-0500</b>	3	N 5	0,004	0,019	14,35
NH-SI 2/ 63A GG AC400V LI AK	2	63	<b>35409-0630</b>	3	N 5	0,004	0,019	14,35
NH-SI 2/ 80A GG AC400V LI AK	2	80	<b>35409-0800</b>	3	N 5	0,004	0,019	14,35
NH-SI 2/ 100A GG AC400V LI AK	2	100	<b>35409-1000</b>	3	N 5	0,004	0,019	14,35
NH-SI 2/ 125A GG AC400V LI AK	2	125	<b>35409-1250</b>	3	N 5	0,004	0,019	14,35
NH-SI 2/ 160A GG AC400V LI AK	2	160	<b>35409-1600</b>	3	N 5	0,004	0,019	14,35
NH-SI 2/ 200A GG AC400V LI AK	2	200	<b>35409-2000</b>	3	N 5	0,004	0,019	14,35
NH-SI 2/ 224A GG AC400V LI AK	2	224	<b>35409-2240</b>	3	N 5	0,004	0,019	14,35
NH-SI 2/ 250A GG AC400V LI AK	2	250	<b>35409-2500</b>	3	N 5	0,004	0,019	14,35
NH-SI 2 300A GG AC400V LI AK	2	300	<b>35409-3000</b>	3	N 5	0,004	0,019	14,35
NH-SI 2 315A GG AC400V LI AK	2	315	<b>35409-3150</b>	3	N 5	0,004	0,019	16,60
NH-SI 2 355A GG AC400V LI AK	2	355	<b>35409-3550</b>	3	N 5	0,004	0,019	20,50
NH-SI 2 400A GG AC400V LI AK	2	400	<b>35409-4000</b>	3	N 5	0,004	0,019	20,50
NH-SI 3/ 250A GG AC400V LI AK	3	250	<b>35410-2500</b>	1	N 5	0,007	0,026	20,90
NH-SI 3/ 300A GG AC400V LI AK	3	300	<b>35410-3000</b>	1	N 5	0,007	0,026	20,90
NH-SI 3/ 315A GG AC400V LI AK	3	315	<b>35410-3150</b>	1	N 5	0,007	0,026	20,90
NH-SI 3/ 400A GG AC400V LI AK	3	400	<b>35410-4000</b>	1	N 5	0,007	0,026	20,90
NH-SI 3/ 425A GG AC400V LI AK	3	425	<b>35410-4250</b>	1	N 5	0,007	0,026	20,90
NH-SI 3 500A GG AC400V LI MA	3	500	<b>35410-5000</b>	1	N 5	0,007	0,026	21,95
NH-SI 3 630A GG AC400V LI MA	3	630	<b>35410-6300</b>	1	N 5	0,007	0,026	21,95

## NH Fuse-Links 500 V gG

- Rated voltage:  
AC 500 V/DC 440 V\*
  - Utilization category:  
gG acc. VDE 0636-2 +  
VDE 0636-1
  - IEC 60269-2
  - Breaking capacity:  
120 kA (AC 500 V)/25 kA  
(DC 440 V)
- \* Size 000-00 DC 250 V
  - \* Size 3 DC 400 V

For more information  
see page 40

Z



35000-0800

### NH Fuse-Links for cable and line protection, AC 500 V gG

#### Properties:

- Twin indicator
- Live metal gripping lugs
- Fuse element copper

Description	Size	Amps	Order-No.	PU	PG	Sur. Ag	Sur. Cu	Price €/pc.
NH-SI 000 2A GG AC500V AK	000	2	35000-0020	10	N 5	0,001	0,003	4,05
NH-SI 000 4,0A GG AC500V AK	000	4	35000-0040	10	N 5	0,001	0,003	4,05
NH-SI 000 6A GG AC500V AK	000	6	35000-0060	10	N 5	0,001	0,003	3,30
NH-SI 000 10A GG AC500V AK	000	10	35000-0100	10	N 5	0,001	0,003	3,30
NH-SI 000 16A GG AC500V AK	000	16	35000-0160	10	N 5	0,001	0,003	3,30
NH-SI 000 20A GG AC500V AK	000	20	35000-0200	10	N 5	0,001	0,003	3,30
NH-SI 000 25A GG AC500V AK	000	25	35000-0250	10	N 5	0,001	0,003	3,30
NH-SI 000 32A GG AC500V AK	000	32	35000-0320	10	N 5	0,001	0,003	3,30
NH-SI 000 35A GG AC500V AK	000	35	35000-0350	10	N 5	0,001	0,003	3,30
NH-SI 000 40A GG AC500V AK	000	40	35000-0400	10	N 5	0,001	0,003	3,30
NH-SI 000 50A GG AC500V AK	000	50	35000-0500	10	N 5	0,001	0,003	3,30
NH-SI 000 63A GG AC500V AK	000	63	35000-0630	10	N 5	0,001	0,003	3,30
NH-SI 000 80A GG AC500V AK	000	80	35000-0800	10	N 5	0,001	0,003	3,30
NH-SI 000 100A GG AC500V AK	000	100	35000-1000	10	N 5	0,001	0,003	3,30
NH-SI 00 25A GG AC500V AK	00	25	35011-0070	3	N 5	0,002	0,004	3,50
NH-SI 00 32A GG AC500V AK	00	32	35011-0080	3	N 5	0,002	0,004	3,50
NH-SI 00 35A GG AC500V AK	00	35	35011-0090	3	N 5	0,002	0,004	3,50
NH-SI 00 40A GG AC500V AK	00	40	35011-0100	3	N 5	0,002	0,004	3,50
NH-SI 00 50A GG AC500V AK	00	50	35011-0110	3	N 5	0,002	0,004	3,50
NH-SI 00 63A GG AC500V AK	00	63	35011-0120	3	N 5	0,002	0,004	3,50
NH-SI 00 80A GG AC500V AK	00	80	35011-0130	3	N 5	0,002	0,004	3,50
NH-SI 00 100A GG AC500V AK	00	100	35011-0140	3	N 5	0,002	0,004	3,50
NH-SI 00 125A GG AC500V AK	00	125	35011-0150	3	N 5	0,002	0,004	3,75
NH-SI 00 160A GG AC500V AK	00	160	35011-1090	3	N 5	0,002	0,007	3,85
NH-SI 1/25A GG AC500V AK	1	25	35035-0050	3	N 6	0,003	0,010	7,75
NH-SI 1/32A GG AC500V AK	1	32	35035-1220	3	N 6	0,003	0,010	9,90
NH-SI 1/35A GG AC500V AK	1	35	35035-0060	3	N 6	0,003	0,010	7,75
NH-SI 1/40A GG AC500V AK	1	40	35035-1230	3	N 6	0,003	0,010	9,90
NH-SI 1/50A GG AC500V AK	1	50	35035-0070	3	N 6	0,003	0,010	7,75
NH-SI 1/63A GG AC500V AK	1	63	35035-0080	3	N 6	0,003	0,010	7,75
NH-SI 1/80A GG AC500V AK	1	80	35035-0090	3	N 6	0,003	0,010	7,75
NH-SI 1/100A GG AC500V AK	1	100	35035-0100	3	N 6	0,003	0,010	7,75
NH-SI 1/125A GG AC500V AK	1	125	35035-0110	3	N 6	0,003	0,010	7,75
NH-SI 1/160A GG AC500V AK	1	160	35035-0120	3	N 6	0,003	0,010	7,75
NH-SI 1 200A GG AC500V AK	1	200	35035-0130	3	N 6	0,003	0,010	9,90
NH-SI 1 224A GG AC500V AK	1	224	35035-0140	3	N 6	0,003	0,010	9,90
NH-SI 1 250A GG AC500V AK	1	250	35035-0150	3	N 6	0,003	0,010	9,90



## NH Fuse-Links 500 V gG

- Rated voltage:  
AC 500 V/DC 440 V\*
  - Utilization category:  
gG acc. VDE 0636-2 +  
VDE 0636-1
  - IEC 60269-2
  - Breaking capacity:  
120 kA (AC 500 V)/25 kA  
(DC 440 V)
- \* Size 000-00 DC 250 V
  - \* Size 3 DC 400 V

For more information  
see page 40



35054-0150

### NH Fuse-Links for cable and line protection, AC 500 V gG

#### Properties:

- Twin indicator (size 4a with middle indicator)
- Live metal gripping lugs
- Fuse element copper

Description	Size	Amps	Order-No.	PU	PG	Sur. Ag	Sur. Cu	Price €/pc.
NH-SI 2/25A GG AC500V AK	2	25	35054-0010	3	N 6	0,004	0,019	11,10
NH-SI 2/35A GG AC500V AK	2	35	35054-0020	3	N 6	0,004	0,019	11,10
NH-SI 2/50A GG AC500V AK	2	50	35054-0030	3	N 6	0,004	0,019	11,10
NH-SI 2/63A GG AC500V AK	2	63	35054-0040	3	N 6	0,004	0,019	11,10
NH-SI 2/80A GG AC500V AK	2	80	35054-0050	3	N 6	0,004	0,019	11,10
NH-SI 2/100A GG AC500V AK	2	100	35054-0060	3	N 6	0,004	0,019	11,10
NH-SI 2/125A GG AC500V AK	2	125	35054-0070	3	N 6	0,004	0,019	11,10
NH-SI 2/160A GG AC500V AK	2	160	35054-0080	3	N 6	0,004	0,019	11,10
NH-SI 2/200A GG AC500V AK	2	200	35054-0090	3	N 6	0,004	0,019	13,20
NH-SI 2/224A GG AC500V AK	2	224	35054-0100	3	N 6	0,004	0,019	13,20
NH-SI 2/250A GG AC500V AK	2	250	35054-0110	3	N 6	0,004	0,019	13,20
NH-SI 2 300A GG AC500V AK	2	300	35054-0120	3	N 6	0,004	0,019	13,20
NH-SI 2 315A GG AC500V AK	2	315	35054-0130	3	N 6	0,004	0,019	13,20
NH-SI 2 355A GG AC500V AK	2	355	35054-0140	3	N 6	0,004	0,019	13,20
NH-SI 2 400A GG AC500V AK	2	400	35054-0150	3	N 6	0,004	0,019	13,20
NH-SI 3/63A GG AC500V AK	3	315	35078-0010	3	N 6	0,007	0,026	19,75
NH-SI 3/80A GG AC500V AK	3	355	35078-0020	3	N 6	0,007	0,026	19,75
NH-SI 3/100A GG AC500V AK	3	400	35078-0030	3	N 6	0,007	0,026	19,75
NH-SI 3/125A GG AC500V AK	3	500	35078-0050	3	N 6	0,007	0,026	22,00
NH-SI 3/160A GG AC500V AK	3	630	35078-0060	3	N 6	0,007	0,026	37,20
NH-SI 3/200A GG AC500V AK	3	300	35078-0190	3	N 6	0,007	0,026	26,40
NH-SI 3/224A GG AC500V AK	3	63	35078-0340	3	N 6	0,007	0,026	19,80
NH-SI 3/250A GG AC500V AK	3	80	35078-0350	3	N 6	0,007	0,026	19,80
NH-SI 3/300A GG AC500V AK	3	100	35078-0360	3	N 6	0,007	0,026	19,80
NH-SI 3/315A GG AC500V AK	3	125	35078-0370	3	N 6	0,007	0,026	19,80
NH-SI 3/355A GG AC500V AK	3	160	35078-0380	3	N 6	0,007	0,026	19,80
NH-SI 3/400A GG AC500V AK	3	200	35078-0390	3	N 6	0,007	0,026	19,80
NH-SI 3 500A GG AC500V AK	3	224	35078-0400	3	N 6	0,007	0,026	19,80
NH-SI 3 630A GG AC500V AK	3	250	35078-0410	3	N 6	0,007	0,026	19,80
NH-SI 4A 400A GG AC500V	4a	400	35097-0120	3	N 7	0,020	0,080	136,00
NH-SI 4A 500A GG AC500V	4a	500	35097-0010	3	N 7	0,020	0,080	136,00
NH-SI 4A 630A GG AC500V	4a	630	35097-0020	3	N 7	0,020	0,080	136,00
NH-SI 4A 800A GG AC500V	4a	800	35097-0030	1	N 7	0,020	0,080	136,00
NH-SI 4A 1000A GG AC500V	4a	1000	35097-0040	1	N 7	0,020	0,080	150,00
NH-SI 4A 1250A GG AC500V	4a	1250	35097-0050	1	N 7	0,020	0,080	165,00
NH-SI 4A 1600A GG AC500V	4a	1600	35097-0110	1	N 7	0,020	0,080	188,00

## NH Fuse-Links 500 V gG

- Rated voltage:  
AC 500 V/DC 440 V\*
- Utilization category:  
gG acc. VDE 0636-2 +  
VDE 0636-1
- IEC 60269-2
- Breaking capacity:  
120 kA (AC 500 V)/25 kA  
(DC 440 V)
- \* Size 00 DC 250 V
- \* Size 3 DC 400 V

For more information  
see page 40

Z



35165-0160

### NH Fuse-Links for cable and line protection, AC 500 V gG

#### Properties:

- Twin indicator
- Dead metal gripping lugs
- Fuse element copper

Description	Size	Amps	Order-No.	PU	PG	Sur. Ag	Sur. Cu	Price €/pc.
NH-SI 00 25A GG AC500V LI AK	00	25	<b>35165-0070</b>	3	N 5	0,002	0,004	4,35
NH-SI 00 32A GG AC500V LI AK	00	32	<b>35165-0080</b>	3	N 5	0,002	0,004	4,35
NH-SI 00 35A GG AC500V LI AK	00	35	<b>35165-0090</b>	3	N 5	0,002	0,004	4,35
NH-SI 00 40A GG AC500V LI AK	00	40	<b>35165-0100</b>	3	N 5	0,002	0,004	4,35
NH-SI 00 50A GG AC500V LI AK	00	50	<b>35165-0110</b>	3	N 5	0,002	0,004	4,35
NH-SI 00 63A GG AC500V LI AK	00	63	<b>35165-0120</b>	3	N 5	0,002	0,004	4,35
NH-SI 00 80A GG AC500V LI AK	00	80	<b>35165-0130</b>	3	N 5	0,002	0,004	4,35
NH-SI 00 100A GG AC500V LI AK	00	100	<b>35165-0140</b>	3	N 5	0,002	0,004	4,65
NH-SI 00 125A GG AC500V LI AK	00	125	<b>35165-0150</b>	3	N 5	0,002	0,004	4,65
NH-SI 00 160A GG AC500V LI AK	00	160	<b>35165-0160</b>	3	N 5	0,002	0,007	4,95
NH-SI 1 25A GG AC500V LI AK	1	25	<b>35204-0050</b>	3	N 6	0,003	0,010	11,20
NH-SI 1 32A GG AC500V LI AK	1	32	<b>35204-0160</b>	3	N 6	0,003	0,010	11,20
NH-SI 1 35A GG AC500V LI AK	1	35	<b>35204-0060</b>	3	N 6	0,003	0,010	11,20
NH-SI 1 40A GG AC500V LI AK	1	40	<b>35204-0170</b>	3	N 6	0,003	0,010	11,20
NH-SI 1 50A GG AC500V LI AK	1	50	<b>35204-0070</b>	3	N 6	0,003	0,010	11,20
NH-SI 1 63A GG AC500V LI AK	1	63	<b>35204-0080</b>	3	N 6	0,003	0,010	11,20
NH-SI 1 80A GG AC500V LI AK	1	80	<b>35204-0090</b>	3	N 6	0,003	0,010	11,20
NH-SI 1 100A GG AC500V LI AK	1	100	<b>35204-0100</b>	3	N 6	0,003	0,010	11,20
NH-SI 1 125A GG AC500V LI AK	1	125	<b>35204-0110</b>	3	N 6	0,003	0,010	11,20
NH-SI 1 160A GG AC500V LI AK	1	160	<b>35204-0120</b>	3	N 6	0,003	0,010	11,60
NH-SI 1 200A GG AC500V LI AK	1	200	<b>35204-0130</b>	3	N 6	0,003	0,010	12,10
NH-SI 1 224A GG AC500V LI AK	1	224	<b>35204-0140</b>	3	N 6	0,003	0,010	12,10
NH-SI 1 250A GG AC500V LI AK	1	250	<b>35204-0150</b>	3	N 6	0,003	0,010	12,10
NH-SI 2 63A GG AC500V LI AK	2	63	<b>35116-0040</b>	3	N 6	0,004	0,019	14,30
NH-SI 2 80A GG AC500V LI AK	2	80	<b>35116-0050</b>	3	N 6	0,004	0,019	14,30
NH-SI 2 100A GG AC500V LI AK	2	100	<b>35116-0060</b>	3	N 6	0,004	0,019	14,30
NH-SI 2 125A GG AC500V LI AK	2	125	<b>35116-0070</b>	3	N 6	0,004	0,019	14,30
NH-SI 2 160A GG AC500V LI AK	2	160	<b>35116-0080</b>	3	N 6	0,004	0,019	14,30
NH-SI 2 200A GG AC500V LI AK	2	200	<b>35116-0090</b>	3	N 6	0,004	0,019	14,30
NH-SI 2 224A GG AC500V LI AK	2	224	<b>35116-0100</b>	3	N 6	0,004	0,019	14,30
NH-SI 2 250A GG AC500V LI AK	2	250	<b>35116-0110</b>	3	N 6	0,004	0,019	14,30
NH-SI 2 300A GG AC500V LI AK	2	300	<b>35116-0120</b>	3	N 6	0,004	0,019	16,50
NH-SI 2 315A GG AC500V LI AK	2	315	<b>35116-0130</b>	3	N 6	0,004	0,019	16,50
NH-SI 2 355A GG AC500V LI AK	2	355	<b>35116-0140</b>	3	N 6	0,004	0,019	16,50
NH-SI 2 400A GG AC500V LI AK	2	400	<b>35116-0150</b>	3	N 6	0,004	0,019	16,50



## NH Fuse-Links 500 V gG

- Rated voltage: AC 500 V/DC 440 V\*      \* Size 000 DC 250 V
- Utilization category: gG acc. VDE 0636-2 + VDE 0636-1
- IEC 60269-2
- Breaking capacity: 120 kA (AC 500 V)/25 kA (DC 440 V)

For more information  
see page 40

### NH Fuse-Links for cable and line protection, AC 500 V gG

#### Properties:

- Twin indicator
- Dead metal gripping lugs
- Fuse element copper

Description	Size	Amps	Order-No.	PU	PG	Sur. Ag	Sur. Cu	Price €/pc.
NH-SI 3/ 100A gG AC500V LI AK	3	100	<b>35420-1000</b>	3	N 5	0,007	0,026	42,30
NH-SI 3/ 125A gG AC500V LI AK	3	125	<b>35420-1250</b>	3	N 5	0,007	0,026	42,30
NH-SI 3/ 160A gG AC500V LI AK	3	160	<b>35420-1600</b>	3	N 5	0,007	0,026	42,30
NH-SI 3/ 200A gG AC500V LI AK	3	200	<b>35420-2000</b>	3	N 5	0,007	0,026	43,00
NH-SI 3/ 224A gG AC500V LI AK	3	224	<b>35420-2240</b>	3	N 5	0,007	0,026	43,00
NH-SI 3/ 250A gG AC500V LI AK	3	250	<b>35420-2500</b>	3	N 5	0,007	0,026	43,00
NH-SI 3/ 300A gG AC500V LI AK	3	300	<b>35420-3000</b>	3	N 5	0,007	0,026	51,50
NH-SI 3/ 315A GG AC500V LI AK	3	315	<b>35420-3150</b>	3	N 5	0,007	0,026	51,50
NH-SI 3/ 355A GG AC500V LI AK	3	355	<b>35420-3550</b>	3	N 5	0,007	0,026	52,00
NH-SI 3/ 400A GG AC500V LI AK	3	400	<b>35420-4000</b>	3	N 5	0,007	0,026	52,00
NH-SI 3 425A GG AC500V LI AK	3	425	<b>35420-4250</b>	3	N 5	0,007	0,026	92,00
NH-SI 3 425A GG AC500V LI AK	3	425	<b>35420-5000</b>	3	N 5	0,007	0,026	92,00
NH-SI 3 630A GG AC500V LI AK	3	630	<b>35420-6300</b>	3	N 5	0,007	0,026	97,00



35001-1000

### NH Fuse-Links for cable and line protection, AC 500 V gG

#### Properties:

- Twin indicator
- Dead gripping lugs of special polymer
- Fuse element copper

Description	Size	Amps	Order-No.	PU	PG	Sur. Ag	Sur. Cu	Price €/pc.
NH-SI 000 2A GG AC500V LP AK	000	2	<b>35001-0020</b>	10	N 5	0,001	0,003	4,35
NH-SI 000 4A GG AC500V LP AK	000	4	<b>35001-0040</b>	10	N 5	0,001	0,003	4,35
NH-SI 000 6A GG AC500V LP AK	000	6	<b>35001-0060</b>	10	N 5	0,001	0,003	4,35
NH-SI 000 10A GG AC500V LP AK	000	10	<b>35001-0100</b>	10	N 5	0,001	0,003	4,35
NH-SI 000 16A GG AC500V LP AK	000	16	<b>35001-0160</b>	10	N 5	0,001	0,003	3,65
NH-SI 000 20A GG AC500V LP AK	000	20	<b>35001-0200</b>	10	N 5	0,001	0,003	3,65
NH-SI 000 25A GG AC500V LP AK	000	25	<b>35001-0250</b>	10	N 5	0,001	0,003	3,65
NH-SI 000 32A GG AC500V LP AK	000	32	<b>35001-0320</b>	10	N 5	0,001	0,003	3,65
NH-SI 000 35A GG AC500V LP AK	000	35	<b>35001-0350</b>	10	N 5	0,001	0,003	3,65
NH-SI 000 40A GG AC500V LP AK	000	40	<b>35001-0400</b>	10	N 5	0,001	0,003	3,65
NH-SI 000 50A GG AC500V LP AK	000	50	<b>35001-0500</b>	10	N 5	0,001	0,003	3,65
NH-SI 000 63A GG AC500V LP AK	000	63	<b>35001-0630</b>	10	N 5	0,001	0,003	3,65
NH-SI 000 80A GG AC500V LP AK	000	80	<b>35001-0800</b>	10	N 5	0,001	0,003	3,65
NH-SI 000 100A GG AC500V LP AK	000	100	<b>35001-1000</b>	10	N 5	0,001	0,003	3,65

## NH Fuse-Links 500 V gL

- Rated voltage: AC 500 V/DC 440 V\*      \* Size 00 DC 220 V
- Utilization category: gL acc. VDE 0636/21 + VDE 0636/1
- IEC 60269-2
- Breaking capacity: 120 kA (AC 500 V)/25 kA (DC 440 V)

**Z**

35207-0130

### NH Fuse-Links for cable and line protection, AC 500 V gL

**Properties:**

- With striker for fuse monitoring
- Live metal gripping lugs
- Fuse element copper

Description	Size	Amps	Order-No.	PU	PG	Sur. Ag	Sur. Cu	Price €/pc.
NH-Si 00 6A gL SM	00	6	<b>35207-0010</b>	10	N 5	0,002	0,004	12,10
NH-Si 00 10A gL SM	00	10	<b>35207-0020</b>	10	N 5	0,002	0,004	12,10
NH-Si 00 16A gL SM	00	16	<b>35207-0030</b>	10	N 5	0,002	0,004	12,10
NH-Si 00 20A gL SM	00	20	<b>35207-0040</b>	10	N 5	0,002	0,004	12,10
NH-Si 00 25A gL SM	00	25	<b>35207-0050</b>	10	N 5	0,002	0,004	12,10
NH-Si 00 32A gL SM	00	32	<b>35207-0060</b>	10	N 5	0,002	0,004	11,10
NH-Si 00 35A gL SM	00	35	<b>35207-0070</b>	10	N 5	0,002	0,004	11,10
NH-Si 00 40A gL SM	00	40	<b>35207-0080</b>	10	N 5	0,002	0,004	11,10
NH-Si 00 50A gL SM	00	50	<b>35207-0090</b>	10	N 5	0,002	0,004	11,10
NH-Si 00 63A gL SM	00	63	<b>35207-0100</b>	10	N 5	0,002	0,004	11,10
NH-Si 00 80A gL SM	00	80	<b>35207-0110</b>	10	N 5	0,002	0,004	11,10
NH-Si 00 100A gL SM	00	100	<b>35207-0120</b>	10	N 5	0,002	0,004	11,10
NH-Si 00 125A gL SM	00	125	<b>35207-0130</b>	10	N 5	0,002	0,004	12,10

## NH Fuse-Links 500 V gL

- Rated voltage: AC 500 V/DC 440 V\*      \* Size 00 DC 220 V
- Utilization category: gL acc. VDE 0636/21 + VDE 0636/1
- IEC 60269-2
- Breaking capacity: 120 kA (AC 500 V)/25 kA (DC 440 V)



35010-0160

### NH Fuse-Links for cable and line protection, AC 500 V gL

#### Properties:

- Middle indicator
- Live metal gripping lugs
- Fuse element pure silver

Description	Size	Amps	Order-No.	PU	PG	Sur. Ag	Sur. Cu	Price €/pc.
NH-SI 00 2A GL AG AC500V	00	2	<b>35010-0010</b>	10	N 1	0,002	0,004	7,75
NH-SI 00 4A GL AG AC500V	00	4	<b>35010-0020</b>	10	N 1	0,002	0,004	7,75
NH-SI 00 6A GL AG AC500V	00	6	<b>35010-0030</b>	10	N 1	0,002	0,004	7,75
NH-SI 00 10A GL AG AC500V	00	10	<b>35010-0040</b>	10	N 1	0,002	0,004	7,75
NH-SI 00 16A GL AG AC500V	00	16	<b>35010-0050</b>	10	N 1	0,003	0,004	7,75
NH-SI 00 20A GL AG AC500V	00	20	<b>35010-0060</b>	10	N 1	0,004	0,004	7,75
NH-SI 00 25A GL AG AC500V	00	25	<b>35010-0070</b>	10	N 1	0,004	0,004	7,75
NH-SI 00 32A GL AG AC500V	00	32	<b>35010-0080</b>	10	N 1	0,004	0,004	6,60
NH-SI 00 35A GL AG AC500V	00	35	<b>35010-0090</b>	10	N 1	0,006	0,004	6,60
NH-SI 00 40A GL AG AC500V	00	40	<b>35010-0100</b>	10	N 1	0,006	0,004	6,60
NH-SI 00 50A GL AG AC500V	00	50	<b>35010-0110</b>	10	N 1	0,008	0,004	6,60
NH-SI 00 63A GL AG AC500V	00	63	<b>35010-0120</b>	10	N 1	0,010	0,004	6,60
NH-SI 00 80A GL AG AC500V	00	80	<b>35010-0130</b>	10	N 1	0,013	0,004	6,60
NH-SI 00 100A GL AG AC500V	00	100	<b>35010-0140</b>	10	N 1	0,016	0,004	6,60
NH-SI 00 125A GL AG AC500V	00	125	<b>35010-0150</b>	10	N 1	0,017	0,004	7,75
NH-SI 00 160A GL AG AC500V	00	160	<b>35010-0160</b>	10	N 1	0,023	0,004	10,60
NH-SI 1/6A GL AG AC500V	1	6	<b>35034-0010</b>	3	N 1	0,004	0,010	11,10
NH-SI 1/10A GL AG AC500V	1	10	<b>35034-0020</b>	3	N 1	0,004	0,010	11,10
NH-SI 1/16A GL AG AC500V	1	16	<b>35034-0030</b>	3	N 1	0,004	0,010	11,10
NH-SI 1/20A GL AG AC500V	1	20	<b>35034-0040</b>	3	N 1	0,004	0,010	11,10
NH-SI 1/25A GL AG AC500V	1	25	<b>35034-0050</b>	3	N 1	0,006	0,010	11,10
NH-SI 1/35A GL AG AC500V	1	35	<b>35034-0060</b>	3	N 1	0,007	0,010	11,10
NH-SI 1/50A GL AG AC500V	1	50	<b>35034-0070</b>	3	N 1	0,009	0,010	11,10
NH-SI 1/63A GL AG AC500V	1	63	<b>35034-0080</b>	3	N 1	0,011	0,010	11,10
NH-SI 1/80A GL AG AC500V	1	80	<b>35034-0090</b>	3	N 1	0,016	0,010	11,10
NH-SI 1/100A GL AG AC500V	1	100	<b>35034-0100</b>	3	N 1	0,018	0,010	11,10
NH-SI 1/125A GL AG AC500V	1	125	<b>35034-0110</b>	3	N 1	0,039	0,010	13,20
NH-SI 1 160A GL AG AC500V	1	160	<b>35034-0120</b>	3	N 1	0,039	0,010	15,95
NH-SI 1 200A GL AG AC500V	1	200	<b>35034-0130</b>	3	N 1	0,041	0,010	23,40
NH-SI 1 224A GL AG AC500V	1	224	<b>35034-0140</b>	3	N 1	0,052	0,010	19,15
NH-SI 1 250A GL AG AC500V	1	250	<b>35034-0150</b>	3	N 1	0,059	0,010	19,15
NH-SI 2/25A GL AG AC500V	2	25	<b>35053-0010</b>	3	N 1	0,008	0,019	15,40
NH-SI 2/35A GL AG AC500V	2	35	<b>35053-0020</b>	3	N 1	0,008	0,019	15,40
NH-SI 2/50A GL AG AC500V	2	50	<b>35053-0030</b>	3	N 1	0,011	0,019	15,40
NH-SI 2/63A GL AG AC500V	2	63	<b>35053-0040</b>	3	N 1	0,013	0,019	15,40
NH-SI 2/80A GL AG AC500V	2	80	<b>35053-0050</b>	3	N 1	0,018	0,019	15,40
NH-SI 2/100A GL AG AC500V	2	100	<b>35053-0060</b>	3	N 1	0,019	0,019	15,40
NH-SI 2/125A GL AG AC500V	2	125	<b>35053-0070</b>	3	N 1	0,025	0,019	16,50
NH-SI 2/160A GL AG AC500V	2	160	<b>35053-0080</b>	3	N 1	0,032	0,019	16,50
NH-SI 2/200A GL AG AC500V	2	200	<b>35053-0090</b>	3	N 1	0,043	0,019	16,50
NH-SI 2/224A GL AG AC500V	2	224	<b>35053-0100</b>	3	N 1	0,056	0,019	18,70
NH-SI 2 250A GL AG AC500V	2	250	<b>35053-0110</b>	3	N 1	0,056	0,019	29,30
NH-SI 2 300A GL AG AC500V	2	300	<b>35053-0120</b>	3	N 1	0,069	0,019	33,00
NH-SI 2 315A GL AG AC500V	2	315	<b>35053-0130</b>	3	N 1	0,069	0,019	33,00
NH-SI 2 355A GL AG AC500V	2	355	<b>35053-0140</b>	3	N 1	0,088	0,019	39,50
NH-SI 2 400A GL AG AC500V	2	400	<b>35053-0150</b>	3	N 1	0,231	0,019	69,00

## NH Fuse-Links 500 V gL

- Rated voltage: AC 500 V/DC 440 V\*      \* Size 00 DC 220 V
- Utilization category: gL acc. VDE 0636/21 + VDE 0636/1
- IEC 60269-2
- Breaking capacity: 120 kA (AC 500 V)/25 kA (DC 440 V)

Z



35164-0160

### NH Fuse-Links for cable and line protection, AC 500 V gL

#### Properties:

- Middle indicator
- dead metal gripping lugs
- Fuse element pure silver

Description	Size	Amps	Order-No.	PU	PG	Sur. Ag	Sur. Cu	Price €/pc.
NH-SI 00 2A GL AG AC500V LI	00	2	<b>35164-0010</b>	10	N 1	0,002	0,004	8,85
NH-SI 00 4A GL AG AC500V LI	00	4	<b>35164-0020</b>	10	N 1	0,002	0,004	8,85
NH-SI 00 6A GL AG AC500V LI	00	6	<b>35164-0030</b>	10	N 1	0,002	0,004	8,85
NH-SI 00 10A GL AG AC500V LI	00	10	<b>35164-0040</b>	10	N 1	0,003	0,004	8,85
NH-SI 00 16A GL AG AC500V LI	00	16	<b>35164-0050</b>	10	N 1	0,004	0,004	8,85
NH-SI 00 20A GL AG AC500V LI	00	20	<b>35164-0060</b>	10	N 1	0,004	0,004	8,85
NH-SI 00 25A GL AG AC500V LI	00	25	<b>35164-0070</b>	10	N 1	0,004	0,004	8,85
NH-SI 00 32A GL AG AC500V LI	00	32	<b>35164-0080</b>	10	N 1	0,006	0,004	7,75
NH-SI 00 35A GL AG AC500V LI	00	35	<b>35164-0090</b>	10	N 1	0,006	0,004	7,75
NH-SI 00 40A GL AG AC500V LI	00	40	<b>35164-0100</b>	10	N 1	0,006	0,004	7,75
NH-SI 00 50A GL AG AC500V LI	00	50	<b>35164-0110</b>	10	N 1	0,008	0,004	7,75
NH-SI 00 63A GL AG AC500V LI	00	63	<b>35164-0120</b>	10	N 1	0,010	0,004	7,75
NH-SI 00 80A GL AG AC500V LI	00	80	<b>35164-0130</b>	10	N 1	0,013	0,004	7,75
NH-SI 00 100A GL AG AC500V LI	00	100	<b>35164-0140</b>	10	N 1	0,016	0,004	7,75
NH-SI 00 125A GL AG AC500V LI	00	125	<b>35164-0150</b>	10	N 1	0,017	0,004	8,80
NH-SI 00 160A GL AG AC500V LI	00	160	<b>35164-0160</b>	10	N 1	0,023	0,004	11,70
NH-SI 1 6A GL AG AC500V LI	1	6	<b>35203-0010</b>	3	N 1	0,004	0,010	13,20
NH-SI 1 10A GL AG AC500V LI	1	10	<b>35203-0020</b>	3	N 1	0,004	0,010	13,20
NH-SI 1 16A GL AG AC500V LI	1	16	<b>35203-0030</b>	3	N 1	0,004	0,010	13,20
NH-SI 1 20A GL AG AC500V LI	1	20	<b>35203-0040</b>	3	N 1	0,004	0,010	13,20
NH-SI 1 25A GL AG AC500V LI	1	25	<b>35203-0050</b>	3	N 1	0,006	0,010	13,20
NH-SI 1 35A GL AG AC500V LI	1	35	<b>35203-0060</b>	3	N 1	0,007	0,010	13,20
NH-SI 1 50A GL AG AC500V LI	1	50	<b>35203-0070</b>	3	N 1	0,009	0,010	13,20
NH-SI 1 63A GL AG AC500V LI	1	63	<b>35203-0080</b>	3	N 1	0,011	0,010	13,20
NH-SI 1 80A GL AG AC500V LI	1	80	<b>35203-0090</b>	3	N 1	0,016	0,010	13,20
NH-SI 1 100A GL AG AC500V LI	1	100	<b>35203-0100</b>	3	N 1	0,018	0,010	15,95
NH-SI 1 125A GL AG AC500V LI	1	125	<b>35203-0110</b>	3	N 1	0,039	0,010	14,35
NH-SI 1 160A GL AG AC500V LI	1	160	<b>35203-0120</b>	3	N 1	0,039	0,010	15,95
NH-SI 1 200A GL AG AC500V LI	1	200	<b>35203-0130</b>	3	N 1	0,041	0,010	19,15
NH-SI 1 224A GL AG AC500V LI	1	224	<b>35203-0140</b>	3	N 1	0,052	0,010	19,15
NH-SI 1 250A GL AG AC500V LI	1	250	<b>35203-0150</b>	3	N 1	0,059	0,010	21,30
NH-SI 2 25A GL AG AC500V LI	2	25	<b>35115-0010</b>	3	N 1	0,008	0,019	18,15
NH-SI 2 35A GL AG AC500V LI	2	35	<b>35115-0020</b>	3	N 1	0,008	0,019	18,15
NH-SI 2 50A GL AG AC500V LI	2	50	<b>35115-0030</b>	3	N 1	0,011	0,019	18,15
NH-SI 2 63A GL AG AC500V LI	2	63	<b>35115-0040</b>	3	N 1	0,013	0,019	18,15
NH-SI 2 80A GL AG AC500V LI	2	80	<b>35115-0050</b>	3	N 1	0,018	0,019	18,95
NH-SI 2 100A GL AG AC500V LI	2	100	<b>35115-0060</b>	3	N 1	0,019	0,019	20,15
NH-SI 2 125A GL AG AC500V LI	2	125	<b>35115-0070</b>	3	N 1	0,025	0,019	22,00
NH-SI 2 160A GL AG AC500V LI	2	160	<b>35115-0080</b>	3	N 1	0,032	0,019	22,00
NH-SI 2 200A GL AG AC500V LI	2	200	<b>35115-0090</b>	3	N 1	0,043	0,019	27,55
NH-SI 2 224A GL AG AC500V LI	2	224	<b>35115-0100</b>	3	N 1	0,056	0,019	26,80
NH-SI 2 250A GL AG AC500V LI	2	250	<b>35115-0110</b>	3	N 1	0,056	0,019	30,85
NH-SI 2 300A GL AG AC500V LI	2	300	<b>35115-0120</b>	3	N 1	0,069	0,019	34,15
NH-SI 2 315A GL AG AC500V LI	2	315	<b>35115-0130</b>	3	N 1	0,069	0,019	34,15
NH-SI 2 355A GL AG AC500V LI	2	355	<b>35115-0140</b>	3	N 1	0,088	0,019	39,65
NH-SI 2 400A GL AG AC500V LI	2	400	<b>35115-0150</b>	3	N 1	0,231	0,019	74,90

## NH Fuse-Links 500 V gL

- Rated voltage: AC 500 V/DC 440 V\*      \* Size 00 DC 220 V
- Utilization category: gL acc. VDE 0636/21 + VDE 0636/1
- IEC 60269-2
- Breaking capacity: 120 kA (AC 500 V)/25 kA (DC 440 V)



35164-0240

### NH Fuse-Links for cable and line protection, AC 500 V gL

#### Properties:

- Middle indicator (specially for meshed network)
- dead metal gripping lugs
- Fuse element pure silver

Description	Size	Amps	Order-No.	PU	PG	Sur. Ag	Sur. Cu	Price €/pc.
NH-SI 00 10A GL AG AC500V LI AU	00	10	<b>35164-0270</b>	10	N 1	0,002	0,004	8,85
NH-SI 00 35A GL AG AC500V LI AU	00	35	<b>35164-0170</b>	10	N 1	0,006	0,004	8,85
NH-SI 00 40A GL AG AC500V LI AU	00	40	<b>35164-0180</b>	10	N 1	0,006	0,004	8,85
NH-SI 00 50A GL AG AC500V LI AU	00	50	<b>35164-0190</b>	10	N 1	0,009	0,004	8,85
NH-SI 00 63A GL AG AC500V LI AU	00	63	<b>35164-0200</b>	10	N 1	0,010	0,004	8,85
NH-SI 00 80A GL AG AC500V LI AU	00	80	<b>35164-0210</b>	10	N 1	0,013	0,004	8,85
NH-SI 00 100A GL AG AC500V LI AU	00	100	<b>35164-0220</b>	10	N 1	0,016	0,004	8,85
NH-SI 00 125A GL AG AC500V LI AU	00	125	<b>35164-0230</b>	10	N 1	0,017	0,004	8,85
NH-SI 00 160A GL AG AC500V LI AU	00	160	<b>35164-0240</b>	10	N 1	0,023	0,004	12,80
NH-SI 00 25A GL AG AC500V LI AU	00	25	<b>35164-0250</b>	10	N 1	0,004	0,004	8,85
NH-SI 00 16A GL AG AC500V LI AU	00	16	<b>35164-0260</b>	10	N 1	0,003	0,004	8,85
NH-SI 2 35A GL AG AC500V LI AU	2	35	<b>35115-0280</b>	3	N 1	0,008	0,019	17,65
NH-SI 2 63A GL AG AC500V LI AU	2	63	<b>35115-0160</b>	3	N 1	0,013	0,019	18,15
NH-SI 2 80A GL AG AC500V LI AU	2	80	<b>35115-0170</b>	3	N 1	0,018	0,019	18,15
NH-SI 2 100A GL AG AC500V LI AU	2	100	<b>35115-0180</b>	3	N 1	0,019	0,019	19,50
NH-SI 2 125A GL AG AC500V LI AU	2	125	<b>35115-0190</b>	3	N 1	0,025	0,019	22,00
NH-SI 2 160A GL AG AC500V LI AU	2	160	<b>35115-0200</b>	3	N 1	0,032	0,019	22,50
NH-SI 2 200A GL AG AC500V LI AU	2	200	<b>35115-0210</b>	3	N 1	0,043	0,019	23,80
NH-SI 2 224A GL AG AC500V LI AU	2	224	<b>35115-0220</b>	3	N 1	0,056	0,019	25,50
NH-SI 2 250A GL AG AC500V LI AU	2	250	<b>35115-0230</b>	3	N 1	0,056	0,019	27,50
NH-SI 2 300A GL AG AC500V LI AU	2	300	<b>35115-0240</b>	3	N 1	0,069	0,019	36,40
NH-SI 2 315A GL AG AC500V LI AU	2	315	<b>35115-0250</b>	3	N 1	0,069	0,019	35,20
NH-SI 2 355A GL AG AC500V LI AU	2	355	<b>35115-0260</b>	3	N 1	0,088	0,019	39,65
NH-SI 2 400A GL AG AC500V LI AU	2	400	<b>35115-0270</b>	3	N 1	0,231	0,019	74,90

# NH Fuse-Links 690 V gG

- Rated voltage: AC 690 V
- Utilization category: gG acc. VDE 0636-2 + VDE 0636-1
- IEC 60269-2 + IEC 60269-1
- Application: For cable and line protection
- Breaking capacity: 100 kA (630 A 50 kA) AC 690 V  
25 kA DC 440 V\*

\* Size 000 DC 250 V  
(Size 3 DC 400 V)

For more information  
see page 40

Z



35421-0250

## NH Fuse-Links for cable and line protection, AC 690 V gG

### Properties:

- Twin indicator
- Live metal gripping lugs
- Fuse element copper

Description	Size	Amps	Order-No.	PU	PG	Sur. Ag	Sur. Cu	Price €/pc.
NH-SI 000 2A GG AC690V AK	000	2	<b>35421-0020</b>	3	N 8	0,002	0,004	7,95
NH-SI 000 4A GG AC690V AK	000	4	<b>35421-0040</b>	3	N 8	0,002	0,004	7,95
NH-SI 000 6A GG AC690V AK	000	6	<b>35421-0060</b>	3	N 8	0,002	0,004	7,95
NH-SI 000 10A GG AC690V AK	000	10	<b>35421-0100</b>	3	N 8	0,002	0,004	7,95
NH-SI 000 16A GG AC690V AK	000	16	<b>35421-0160</b>	3	N 8	0,002	0,004	7,95
NH-SI 000 20A GG AC690V AK	000	20	<b>35421-0200</b>	3	N 8	0,002	0,004	7,95
NH-SI 000 25A GG AC690V AK	000	25	<b>35421-0250</b>	3	N 8	0,002	0,004	7,95
NH-SI 000 32A GG AC690V AK	000	32	<b>35421-0320</b>	3	N 8	0,002	0,004	7,95
NH-SI 000 35A GG AC690V AK	000	35	<b>35421-0350</b>	3	N 8	0,002	0,004	7,75
NH-SI 000 40A GG AC690V AK	000	40	<b>35421-0400</b>	3	N 8	0,002	0,004	7,75
NH-SI 000 50A GG AC690V AK	000	50	<b>35421-0500</b>	3	N 8	0,002	0,004	7,75
NH-SI 000 63A GG AC690V AK	000	63	<b>35421-0630</b>	3	N 8	0,002	0,004	7,75
NH-SI 00 80A GG AC690V AK	00	80	<b>35422-0800</b>	3	N 8	0,002	0,004	7,95
NH-SI 00 100A GG AC690V AK	00	100	<b>35422-1000</b>	3	N 8	0,002	0,004	7,95
NH-SI 00 125A GG AC690V AK	00	125	<b>35422-1250</b>	3	N 8	0,002	0,004	7,95
NH-SI 1/ 25A GG AC690V AK	1	25	<b>35423-0250</b>	3	N 8	0,003	0,010	13,20
NH-SI 1/ 32A GG AC690V AK	1	32	<b>35423-0320</b>	3	N 8	0,003	0,010	13,20
NH-SI 1/ 35A GG AC690V AK	1	35	<b>35423-0350</b>	3	N 8	0,003	0,010	13,20
NH-SI 1/ 40A GG AC690V AK	1	40	<b>35423-0400</b>	3	N 8	0,003	0,010	13,20
NH-SI 1/ 50A GG AC690V AK	1	50	<b>35423-0500</b>	3	N 8	0,003	0,010	13,20
NH-SI 1/ 63A GG AC690V AK	1	63	<b>35423-0630</b>	3	N 8	0,003	0,010	13,20
NH-SI 1/ 80A GG AC690V AK	1	80	<b>35423-0800</b>	3	N 8	0,003	0,010	13,20
NH-SI 1/ 100A GG AC690V AK	1	100	<b>35423-1000</b>	3	N 8	0,003	0,010	13,20
NH-SI 1 125A GG AC690V AK	1	125	<b>35423-1250</b>	3	N 8	0,003	0,010	13,20
NH-SI 1 160A GG AC690V AK	1	160	<b>35423-1600</b>	3	N 8	0,003	0,010	13,20
NH-SI 1 200A GG AC690V AK	1	200	<b>35423-2000</b>	3	N 8	0,003	0,010	14,40
NH-SI 1 250A GG AC690V AK	2	250	<b>35423-2500</b>	3	N 8	0,003	0,010	14,40
NH-SI 2/ 25A GG AC690V AK	2	25	<b>35424-0250</b>	3	N 8	0,004	0,018	17,65
NH-SI 2/ 35A GG AC690V AK	2	35	<b>35424-0350</b>	3	N 8	0,004	0,018	17,65
NH-SI 2/ 50A GG AC690V AK	2	50	<b>35424-0500</b>	3	N 8	0,004	0,018	17,65
NH-SI 2/ 63A GG AC690V AK	2	63	<b>35424-0630</b>	3	N 8	0,004	0,018	17,65
NH-SI 2/ 80A GG AC690V AK	2	80	<b>35424-0800</b>	3	N 8	0,004	0,018	17,65
NH-SI 2/ 100A GG AC690V AK	2	100	<b>35424-1000</b>	3	N 8	0,004	0,018	17,65
NH-SI 2/ 125A GG AC690V AK	2	125	<b>35424-1250</b>	3	N 8	0,004	0,018	18,75
NH-SI 2/ 160A GG AC690V AK	2	160	<b>35424-1600</b>	3	N 8	0,004	0,018	18,75
NH-SI 2/ 200A GG AC690V AK	2	200	<b>35424-2000</b>	3	N 8	0,004	0,018	18,75
NH-SI 2/ 250A GG AC690V AK	2	250	<b>35424-2500</b>	3	N 8	0,004	0,018	20,95
NH-SI 2 315A GG AC690V AK	2	315	<b>35424-3150</b>	3	N 8	0,004	0,018	23,10
NH-SI 2 355A GG AC690V AK	2	355	<b>35424-3550</b>	3	N 8	0,004	0,018	23,10
NH-SI 2 400A GG AC690V AK	2	400	<b>35424-4000</b>	3	N 8	0,004	0,018	23,10



## NH Fuse-Links 690 V gG

- Rated voltage: AC 690 V
- Utilization category: gG acc. VDE 0636-2 + VDE 0636-1
- IEC 60269-2 + IEC 60269-1
- Application: For cable and line protection
- Breaking capacity: 100 kA (630 A 50 kA) AC 690 V  
25 kA DC 440 V\*

\* Size 000 DC 250 V  
(Size 3 DC 400 V)

For more information  
see page **40**



35425-4000

### NH Fuse-Links for cable and line protection, AC 690 V gG

#### Properties:

- Twin indicator ( 630 A with middle indicator)
- Live metal gripping lugs
- Fuse element copper

Description	Size	Amps	Order-No.	PU	PG	Sur. Ag	Sur. Cu	Price €/pc.
NH-SI 3/ 80A GG AC690V AK	3	80	<b>35425-0800</b>	3	N 8	0,007	0,026	29,80
NH-SI 3/ 100A GG AC690V AK	3	100	<b>35425-1000</b>	3	N 8	0,007	0,026	29,80
NH-SI 3/ 125A GG AC690V AK	3	125	<b>35425-1250</b>	3	N 8	0,007	0,026	29,80
NH-SI 3/ 160A GG AC690V AK	3	160	<b>35425-1600</b>	3	N 8	0,007	0,026	29,80
NH-SI 3/ 200A GG AC690V AK	3	200	<b>35425-2000</b>	3	N 8	0,007	0,026	29,80
NH-SI 3/ 224A GG AC690V AK	3	224	<b>35425-2240</b>	3	N 8	0,007	0,026	29,80
NH-SI 3/ 250A GG AC690V AK	3	250	<b>35425-2500</b>	3	N 8	0,007	0,026	29,80
NH-SI 3/ 315A GG AC690V AK	3	315	<b>35425-3150</b>	3	N 8	0,007	0,026	31,95
NH-SI 3/ 355A GG AC690V AK	3	355	<b>35425-3550</b>	3	N 8	0,007	0,026	31,95
NH-SI 3 400A GG AC690V AK	3	400	<b>35425-4000</b>	3	N 8	0,007	0,026	31,95
NH-SI 3 500A GG AC690V AK	3	500	<b>35425-5000</b>	3	N 8	0,007	0,026	34,15
NH-SI 3 630A GG AC690V MA	3	630	<b>35425-6300</b>	3	N 8	0,007	0,026	on demand

## NH Fuse-Links 400 V gTr

- Rated voltage:  
AC 400 V gTr
- Utilization category:  
gTr acc. VDE 0636/2011
- Application:  
For transformer protection
- Breaking capacity:  
100 kA

**Z**

 For more information  
see page **40**

35081-0110

### NH Fuse-Links for transformer protection, AC 400 V gTr

**Properties:**

- Middle indicator
- Live metal gripping lugs
- Fuse element copper

Description	Size	Amps	Order-No.	PU	PG	Sur. Ag	Sur. Cu	Price €/pc.
NH-SI 2 50KVA GTR AC400V MA	2	72	<b>35076-1010</b>	3	N 7	0,004	0,019	28,60
NH-SI 2 75KVA GTR AC400V MA	2	108	<b>35076-1020</b>	3	N 7	0,004	0,019	28,60
NH-SI 2 100KVA GTR AC400V MA	2	144	<b>35076-1030</b>	3	N 7	0,004	0,019	28,60
NH-SI 2 125KVA GTR AC400V MA	2	180	<b>35076-1040</b>	3	N 7	0,004	0,019	28,60
NH-SI 2 160KVA GTR AC400V MA	2	231	<b>35076-1050</b>	3	N 7	0,004	0,019	28,60
NH-SI 2 200KVA GTR AC400V MA	2	289	<b>35076-1060</b>	3	N 7	0,004	0,019	30,85
NH-SI 2 250KVA GTR AC400V MA	2	361	<b>35076-1070</b>	3	N 7	0,004	0,019	31,90
NH-SI 3 100KVA GTR AC400V MA	3	144	<b>35081-1040</b>	1	N 7	0,005	0,026	44,00
NH-SI 3 160KVA GTR AC400V MA	3	231	<b>35081-1060</b>	1	N 7	0,005	0,026	44,00
NH-SI 3 200KVA GTR AC400V MA	3	289	<b>35081-1050</b>	1	N 7	0,005	0,026	44,00
NH-SI 3 250KVA GTR AC400V MA	3	361	<b>35081-1010</b>	1	N 7	0,005	0,026	44,00
NH-SI 3 315KVA GTR AC400V MA	3	455	<b>35081-1020</b>	1	N 7	0,005	0,026	44,00
NH-SI 3 400KVA GTR AC400V MA	3	577	<b>35081-1030</b>	1	N 7	0,005	0,026	44,00
NH-SI 3 500KVA GTR AC400V MA	3	722	<b>35081-0100</b>	1	N 7	0,020	0,080	88,00
NH-SI 3 630KVA GTR AC400V MA	3	909	<b>35081-0110</b>	1	N 7	0,020	0,080	88,00
NH-SI 4A 100KVA GTR AC400V MA	4a	144	<b>35100-0100</b>	1	N 7	0,020	0,080	128,00
NH-SI 4A 160KVA GTR AC400V MA	4a	231	<b>35100-0110</b>	1	N 7	0,020	0,080	128,00
NH-SI 4A 200KVA GTR AC400V MA	4a	289	<b>35100-0160</b>	1	N 7	0,020	0,080	128,00
NH-SI 4A 250KVA GTR AC400V MA	4a	361	<b>35100-0120</b>	1	N 7	0,020	0,080	128,00
NH-SI 4A 315KVA GTR AC400V MA	4a	455	<b>35100-0170</b>	1	N 7	0,020	0,080	128,00
NH-SI 4A 400KVA GTR AC400V MA	4a	577	<b>35100-0130</b>	1	N 7	0,020	0,080	132,00
NH-SI 4A 500KVA GTR AC400V MA	4a	722	<b>35100-0140</b>	1	N 7	0,020	0,080	132,00
NH-SI 4A 630KVA GTR AC400V MA	4a	909	<b>35100-0150</b>	1	N 7	0,020	0,080	132,00
NH-SI 4A 800KVA GTR AC400V MA	4a	1155	<b>35100-0040</b>	1	N 7	0,020	0,080	132,00
NH-SI 4A 1000KVA GTR AC400V	4a	1443	<b>35100-0190</b>	1	N 7	0,020	0,080	132,00

## NH Fuse-Links 500 V gR

- Rated voltage: AC 500 V
- Utilization category: gR acc. VDE 0636/4
- Application: For protection of semiconductors
- Breaking capacity: 120 kA (AC 500 V)  
25 kA (DC 440 V) \*

\* Size 00 80-160 A DC 240 V

For more information  
see page 40



35058-0110

### NH Fuse-Links for protection of semiconductors, AC 500 V gR

#### Properties:

- Middle indicator
- Live metal gripping lugs
- Fuse element pure silver

Description	Size	Amps	Order-No.	PU	PG	Sur. Ag	Sur. Cu	Price €/pc.
NH-SI 00 16A GR AC500V LS	00	16	35024-0180	10	N 2	0,003	0,004	15,45
NH-SI 00 20A GR AC500V LS	00	20	35024-0170	10	N 2	0,003	0,004	15,45
NH-SI 00 25A GR AC500V LS	00	25	35024-0190	10	N 2	0,003	0,004	15,45
NH-SI 00 35A GR AC500V LS	00	35	35024-0010	10	N 2	0,008	0,004	14,90
NH-SI 00 40A GR AC500V LS	00	40	35024-0020	10	N 2	0,008	0,004	15,40
NH-SI 00 50A GR AC500V LS	00	50	35024-0030	10	N 2	0,010	0,004	15,40
NH-SI 00 63A GR AC500V LS	00	63	35024-0040	10	N 2	0,010	0,004	15,40
NH-SI 00 80A GR AC500V LS	00	80	35024-0050	10	N 2	0,010	0,004	15,40
NH-SI 00 100A GR AC500V LS	00	100	35024-0060	10	N 2	0,010	0,004	16,45
NH-SI 00 125A GR AC500V LS	00	125	35024-0070	10	N 2	0,012	0,004	19,80
NH-SI 00 160A GR AC500V LS	00	160	35024-0080	10	N 2	0,015	0,004	21,95
NH-SI 1 35A GR AC500V LS	1	35	35040-0010	3	N 2	0,011	0,010	30,85
NH-SI 1 50A GR AC500V LS	1	50	35040-0020	3	N 2	0,012	0,010	30,85
NH-SI 1 63A GR AC500V LS	1	63	35040-0030	3	N 2	0,017	0,010	30,85
NH-SI 1 80A GR AC500V LS	1	80	35040-0040	3	N 2	0,022	0,010	30,85
NH-SI 1 100A GR AC500V LS	1	100	35040-0050	3	N 2	0,024	0,010	33,00
NH-SI 1 125A GR AC500V LS	1	125	35040-0060	3	N 2	0,033	0,010	33,00
NH-SI 1 160A GR AC500V LS	1	160	35040-0070	3	N 2	0,043	0,010	33,00
NH-SI 1 200A GR AC500V LS	1	200	35040-0080	3	N 2	0,053	0,010	33,00
NH-SI 1 224A GR AC500V LS	1	224	35040-0090	3	N 2	0,063	0,010	36,40
NH-SI 1 250A GR AC500V LS	1	250	35040-0100	3	N 2	0,070	0,010	36,40
NH-SI 2 80A GR AC500V LS	2	80	35058-0010	3	N 2	0,023	0,019	37,50
NH-SI 2 100A GR AC500V LS	2	100	35058-0020	3	N 2	0,026	0,019	37,50
NH-SI 2 125A GR AC500V LS	2	125	35058-0030	3	N 2	0,036	0,019	37,50
NH-SI 2 160A GR AC500V LS	2	160	35058-0040	3	N 2	0,046	0,019	38,50
NH-SI 2 200A GR AC500V LS	2	200	35058-0050	3	N 2	0,056	0,019	39,60
NH-SI 2 224A GR AC500V LS	2	224	35058-0060	3	N 2	0,064	0,019	41,80
NH-SI 2 250A GR AC500V LS	2	250	35058-0070	3	N 2	0,071	0,019	41,80
NH-SI 2 300A GR AC500V LS	2	300	35058-0080	3	N 2	0,116	0,019	46,30
NH-SI 2 315A GR AC500V LS	2	315	35058-0090	3	N 2	0,128	0,019	50,70
NH-SI 2 355A GR AC500V LS	2	355	35058-0100	3	N 2	0,153	0,019	50,70
NH-SI 2 400A GR AC500V LS	2	400	35058-0110	3	N 2	0,159	0,019	53,90
NH-SI 3 315A GR AC500V LS	3	315	35079-0010	1	N 2	0,133	0,026	61,70
NH-SI 3 355A GR AC500V LS	3	355	35079-0020	1	N 2	0,154	0,026	61,70
NH-SI 3 400A GR AC500V LS	3	400	35079-0030	1	N 2	0,161	0,026	66,00
NH-SI 3 425A GR AC500V LS	3	425	35079-0040	1	N 2	0,178	0,026	66,00
NH-SI 3 500A GR AC500V LS	3	500	35079-0050	1	N 2	0,184	0,026	71,60
NH-SI 3 630A GR AC500V LS	3	630	35079-0060	1	N 2	0,232	0,026	77,10

## NH Fuse-Links 500 V gR

- Rated voltage: AC 500 V
  - Utilization category: gR acc. VDE 0636/4
  - Application: For protection of semiconductors
  - Breaking capacity: 120 kA (AC 500 V)  
25 kA (DC 440 V)\*
- \* Size 00 80 A - 160 A DC 240 V

For more information  
see page 40

Z



35060-0150

### NH Fuse-Links for protection of semiconductors, AC 500 V gR

#### Properties:

- Middle indicator
- Live metal gripping lugs
- Fuse element pure silver
- With striker

Description	Size	Amps	Order-No.	PU	PG	Sur. Ag	Sur. Cu	Price €/pc.
NH-SI 00 16A GR AC500V SM	00	16	<b>35218-0010</b>	10	N 2	0,002	0,001	24,20
NH-SI 00 20A GR AC500V SM	00	20	<b>35218-0020</b>	10	N 2	0,002	0,001	24,20
NH-SI 00 25A GR AC500V SM	00	25	<b>35218-0030</b>	10	N 2	0,002	0,001	24,20
NH-SI 00 35A GR AC500V SM	00	35	<b>35218-0040</b>	10	N 2	0,007	0,001	24,20
NH-SI 00 40A GR AC500V SM	00	40	<b>35218-0050</b>	10	N 2	0,007	0,001	24,20
NH-SI 00 50A GR AC500V SM	00	50	<b>35218-0060</b>	10	N 2	0,009	0,001	24,20
NH-SI 00 63A GR AC500V SM	00	63	<b>35218-0070</b>	10	N 2	0,006	0,001	24,20
NH-SI 00 80A GR AC500V SM	00	80	<b>35218-0080</b>	10	N 2	0,008	0,001	24,20
NH-SI 00 100A GR AC500V SM	00	100	<b>35218-0090</b>	10	N 2	0,009	0,001	25,40
NH-SI 00 125A GR AC500V SM	00	125	<b>35218-0100</b>	10	N 2	0,012	0,001	28,60
NH-SI 1 35A GR AC500V LS SM	1	35	<b>35046-0010</b>	1	N 2	0,011	0,012	48,40
NH-SI 1 50A GR AC500V LS SM	1	50	<b>35046-0020</b>	1	N 2	0,012	0,012	48,40
NH-SI 1 63A GR AC500V LS SM	1	63	<b>35046-0030</b>	1	N 2	0,017	0,012	48,40
NH-SI 1 80A GR AC500V LS SM	1	80	<b>35046-0040</b>	1	N 2	0,022	0,012	48,40
NH-SI 1 100A GR AC500V LS SM	1	100	<b>35046-0050</b>	1	N 2	0,024	0,012	49,60
NH-SI 1 160A GR AC500V LS SM	1	160	<b>35046-0070</b>	1	N 2	0,043	0,012	50,60
NH-SI 1 200A GR AC500V LS SM	1	200	<b>35046-0080</b>	1	N 2	0,053	0,012	50,60
NH-SI 1 224A GR AC500V LS SM	1	224	<b>35046-0090</b>	1	N 2	0,063	0,012	52,90
NH-SI 1 250A GR AC500V LS SM	1	250	<b>35046-0100</b>	1	N 2	0,070	0,012	52,90
NH-SI 2 80A GR AC500V LS SM	2	80	<b>35060-0050</b>	1	N 2	0,023	0,018	53,90
NH-SI 2 100A GR AC500V LS SM	2	100	<b>35060-0060</b>	1	N 2	0,026	0,018	53,90
NH-SI 2 125A GR AC500V LS SM	2	125	<b>35060-0070</b>	1	N 2	0,036	0,018	53,90
NH-SI 2 160A GR AC500V LS SM	2	160	<b>35060-0080</b>	1	N 2	0,046	0,018	55,10
NH-SI 2 200A GR AC500V LS SM	2	200	<b>35060-0090</b>	1	N 2	0,056	0,018	56,15
NH-SI 2 224A GR AC500V LS SM	2	224	<b>35060-0100</b>	1	N 2	0,064	0,018	59,45
NH-SI 2 250A GR AC500V LS SM	2	250	<b>35060-0110</b>	1	N 2	0,071	0,018	59,45
NH-SI 2 300A GR AC500V LS SM	2	300	<b>35060-0120</b>	1	N 2	0,116	0,018	62,80
NH-SI 2 315A GR AC500V LS SM	2	315	<b>35060-0130</b>	1	N 2	0,128	0,018	67,10
NH-SI 2 355A GR AC500V LS SM	2	355	<b>35060-0140</b>	1	N 2	0,153	0,018	67,10
NH-SI 2 400A GR AC500V LS SM	2	400	<b>35060-0150</b>	1	N 2	0,159	0,018	70,40
NH-SI 3 315A GR AC500V LS SM	3	315	<b>35086-0010</b>	1	N 2	0,133	0,026	79,20
NH-SI 3 355A GR AC500V LS SM	3	355	<b>35086-0020</b>	1	N 2	0,154	0,026	79,20
NH-SI 3 400A GR AC500V LS SM	3	400	<b>35086-0030</b>	1	N 2	0,161	0,026	87,00
NH-SI 3 425A GR AC500V LS SM	3	425	<b>35086-0040</b>	1	N 2	0,178	0,026	87,00
NH-SI 3 500A GR AC500V LS SM	3	500	<b>35086-0050</b>	1	N 2	0,184	0,026	88,00
NH-SI 3 630A GR AC500V LS SM	3	630	<b>35086-0060</b>	1	N 2	0,207	0,026	88,00

## NH Fuse-Links 500 V gR

- Rated voltage:  
AC 500 V
- Utilization category:  
gR acc. VDE 0636/4
- Application:  
For protection of  
semiconductors
- Breaking capacity:  
120 kA

For more information  
see page **40**



35209-0050

### NH Maintenance Fuse-Link 500 V gR

#### Properties:

- Special marking
- dead metal gripping lugs
- Fuse element pure silver

Description	Size	Amps	Order-No.	PU	PG	Sur. Ag	Sur. Cu	Price €/pc.
NH-ARBEITSSICHERUNG 2 80A GR AC500V LI	2	80	<b>35209-0010</b>	3	N 5	0,023	0,019	38,50
NH-ARBEITSSICHERUNG 2 100A GR AC500V LI	2	100	<b>35209-0020</b>	3	N 5	0,026	0,019	38,50
NH-ARBEITSSICHERUNG 2 125A GR AC500V LI	2	125	<b>35209-0030</b>	3	N 5	0,036	0,019	38,50
NH-ARBEITSSICHERUNG 2 160A GR AC500V LI	2	160	<b>35209-0040</b>	3	N 5	0,046	0,019	39,70
NH-ARBEITSSICHERUNG 2 200A GR AC500V LI	2	200	<b>35209-0050</b>	3	N 5	0,056	0,019	40,75
NH-ARBEITSSICHERUNG 2 224A GR AC500V LI	2	224	<b>35209-0060</b>	3	N 5	0,064	0,019	42,95
NH-ARBEITSSICHERUNG 2 250A GR AC500V LI	2	250	<b>35209-0070</b>	3	N 5	0,071	0,019	42,95
NH-ARBEITSSICHERUNG 2 300A GR AC500V LI	2	300	<b>35209-0080</b>	3	N 5	0,116	0,019	47,35
NH-ARBEITSSICHERUNG 2 315A GR AC500V LI	2	315	<b>35209-0090</b>	3	N 5	0,128	0,019	51,75

## NH Fuse-Links 1000 V gB/aM

 For more information  
see page 40

**Z**

35041-0180

### NH Fuse-Links 1L, 1000 V gB

**Properties:**

- AC 1000 V, DC 550 V
- Breaking capacity 25 kA
- gB acc. VDE 0636/2011

Description	Size	Amps	Order-No.	PU	PG	Sur. Ag	Sur. Cu	Price €/pc.
NH-SI 1L 10A GB AC1000V LS AS	1L	10	<b>35041-0410</b>	1	N 4	0,005	0,018	40,75
NH-SI 1L 16A GB AC1000V LS AS	1L	16	<b>35041-0420</b>	1	N 4	0,006	0,019	40,75
NH-SI 1L 35A GB AC1000V LS AS	1L	35	<b>35041-0100</b>	1	N 4	0,009	0,019	39,70
NH-SI 1L 50A GB AC1000V LS AS	1L	50	<b>35041-0110</b>	1	N 4	0,013	0,019	39,70
NH-SI 1L 63A GB AC1000V LS AS	1L	63	<b>35041-0120</b>	1	N 4	0,017	0,019	39,70
NH-SI 1L 80A GB AC1000V LS AS	1L	80	<b>35041-0130</b>	1	N 4	0,021	0,019	39,70
NH-SI 1L 100A GB AC1000V LS AS	1L	100	<b>35041-0140</b>	1	N 4	0,028	0,019	39,70
NH-SI 1L 125A GB AC1000V LS AS	1L	125	<b>35041-0150</b>	1	N 4	0,038	0,019	39,70
NH-SI 1L 160A GB AC1000V LS AS	1L	160	<b>35041-0160</b>	1	N 4	0,042	0,019	39,70
NH-SI 1L 200A GB AC1000V LS AS	1L	200	<b>35041-0170</b>	1	N 4	0,054	0,019	40,75
NH-SI 1L 250A GB AC1000V LS AS	1L	250	<b>35041-0180</b>	1	N 4	0,068	0,019	46,25



35151-0020

### NH Fuse-Links for back up protection by mining equipment

**Properties:**

- AC 1000 V (425-500 A) and AC 1500 V (10-355 A)
- Breaking capacity 25 kA
- aM acc. VDE 0636/22

Description	Size	Amps	Order-No.	PU	PG	Sur. Ag	Sur. Cu	Price €/pc.
NH-SI 3 125A AM AC1000V SBW	3	125	<b>35151-0010</b>	1	N 3	0,055	0,003	99,15
NH-SI 3 160A AM AC1000V SBW	3	160	<b>35151-0020</b>	1	N 3	0,071	0,003	99,15
NH-SI 3 200A AM AC1000V SBW	3	200	<b>35151-0030</b>	1	N 3	0,079	0,003	102,50
NH-SI 3 224A AM AC1000V SBW	3	224	<b>35151-0040</b>	1	N 3	0,093	0,003	104,50
NH-SI 3 250A AM AC1000V SBW	3	250	<b>35151-0050</b>	1	N 3	0,102	0,003	109,00
NH-SI 3 315A AM AC1000V SBW	3	315	<b>35151-0070</b>	1	N 3	0,126	0,003	112,30
NH-SI 3 355A AM AC1000V SBW	3	355	<b>35151-0080</b>	1	N 3	0,150	0,003	119,00
NH-SI 3 500A AM AC1000V SBW	3	500	<b>35151-0120</b>	1	N 3	0,293	0,003	143,00



## NH Fuse-Links 1000 V / 1500 V TF

 For more information  
see page 40

35150-0180

**NH Fuse-Links for back up protection by mining equipment**
**Properties:**

- AC 1000 V
- Breaking capacity 25 kA
- TF acc. VDE 0660 and DIN 43620/5

Description	Size	Amps	Order-No.	PU	PG	Sur. Ag	Sur. Cu	Price €/pc.
NH-SI 3 10A TF AC1000V RHB	3	10	<b>35150-0010</b>	1	N 3	0,008	0,003	115,60
NH-SI 3 16A TF AC1000V RHB	3	16	<b>35150-0020</b>	1	N 3	0,010	0,003	115,60
NH-SI 3 20A TF AC1000V RHB	3	20	<b>35150-0030</b>	1	N 3	0,012	0,003	115,60
NH-SI 3 25A TF AC1000V RHB	3	25	<b>35150-0040</b>	1	N 3	0,014	0,003	115,60
NH-SI 3 35A TF AC1000V RHB	3	35	<b>35150-0050</b>	1	N 3	0,016	0,003	115,60
NH-SI 3 50A TF AC1000V RHB	3	50	<b>35150-0060</b>	1	N 3	0,019	0,003	115,60
NH-SI 3 63A TF AC1000V RHB	3	63	<b>35150-0070</b>	1	N 3	0,021	0,003	118,90
NH-SI 3 80A TF AC1000V RHB	3	80	<b>35150-0080</b>	1	N 3	0,028	0,003	118,90
NH-SI 3 100A TF AC1000V RHB	3	100	<b>35150-0090</b>	1	N 3	0,030	0,003	118,90
NH-SI 3 125A TF AC1000V RHB	3	125	<b>35150-0100</b>	1	N 3	0,040	0,003	118,90
NH-SI 3 160A TF AC1000V RHB	3	160	<b>35150-0110</b>	1	N 3	0,056	0,003	118,90
NH-SI 3 200A TF AC1000V RHB	3	200	<b>35150-0120</b>	1	N 3	0,083	0,003	122,10
NH-SI 3 224A TF AC1000V RHB	3	224	<b>35150-0130</b>	1	N 3	0,083	0,003	122,10
NH-SI 3 250A TF AC1000V RHB	3	250	<b>35150-0140</b>	1	N 3	0,083	0,003	122,10
NH-SI 3 300A TF AC1000V RHB	3	300	<b>35150-0150</b>	1	N 3	0,121	0,003	127,70
NH-SI 3 315A TF AC1000V RHB	3	315	<b>35150-0160</b>	1	N 3	0,121	0,003	131,00
NH-SI 3 355A TF AC1000V RHB	3	355	<b>35150-0170</b>	1	N 3	0,121	0,003	131,00
NH-SI 3 400A TF AC1000V RHB	3	400	<b>35150-0190</b>	1	N 3	0,121	0,003	131,00
NH-SI 3 425A TF AC1000V RHB	3	425	<b>35150-0180</b>	1	N 3	0,121	0,003	131,00



35091-0190

**NH Fuse-Links size 3L, Specialdesign**
**Properties:**

- AC 1000 V (425-500 A) and AC 1500 V (10-355 A)
- Breaking capacity: 10 kA (AC 1500 V); 50 kA (AC 1000 V), 25 kA DC 750 V 10-355 A
- TF acc. VDE 0660 and DIN 43620/5
- Striker for fusemonitoring

Description	Size	Amps	Order-No.	PU	PG	Sur. Ag	Sur. Cu	Price €/pc.
NH-SI 3L 10A TF AC1500V SM	3L	10	<b>35091-0010</b>	1	N 3	0,012	0,026	157,00
NH-SI 3L 16A TF AC1500V SM	3L	16	<b>35091-0020</b>	1	N 3	0,014	0,026	157,00
NH-SI 3L 20A TF AC1500V SM	3L	20	<b>35091-0030</b>	1	N 3	0,015	0,026	157,00
NH-SI 3L 25A TF AC1500V SM	3L	25	<b>35091-0040</b>	1	N 3	0,017	0,026	157,00
NH-SI 3L 35A TF AC1500V SM	3L	35	<b>35091-0050</b>	1	N 3	0,017	0,026	157,00
NH-SI 3L 50A TF AC1500V SM	3L	50	<b>35091-0060</b>	1	N 3	0,021	0,026	157,00
NH-SI 3L 63A TF AC1500V SM	3L	63	<b>35091-0070</b>	1	N 3	0,022	0,026	157,00
NH-SI 3L 80A TF AC1500V SM	3L	80	<b>35091-0080</b>	1	N 3	0,028	0,026	157,00
NH-SI 3L 100A TF AC1500V SM	3L	100	<b>35091-0090</b>	1	N 3	0,035	0,026	157,00
NH-SI 3L 125A TF AC1500V SM	3L	125	<b>35091-0100</b>	1	N 3	0,048	0,026	157,00
NH-SI 3L 160A TF AC1500V SM	3L	160	<b>35091-0110</b>	1	N 3	0,069	0,026	163,00
NH-SI 3L 200A TF AC1500V SM	3L	200	<b>35091-0120</b>	1	N 3	0,089	0,026	163,00
NH-SI 3L 224A TF AC1500V SM	3L	224	<b>35091-0130</b>	1	N 3	0,099	0,026	165,00
NH-SI 3L 250A TF AC1500V SM	3L	250	<b>35091-0140</b>	1	N 3	0,110	0,026	165,00
NH-SI 3L 300A TF AC1500V SM	3L	300	<b>35091-0150</b>	1	N 3	0,130	0,026	175,00
NH-SI 3L 315A TF AC1500V SM	3L	315	<b>35091-0160</b>	1	N 3	0,140	0,026	175,00
NH-SI 3L 355A TF AC1500V SM	3L	355	<b>35091-0170</b>	1	N 3	0,150	0,026	175,00
NH-SI 3L 425A TF AC1000V SM	3L	425	<b>35091-0180</b>	1	N 3	0,198	0,026	179,00
NH-SI 3L 500A TF AC1000V SM	3L	500	<b>35091-0190</b>	1	N 3	0,217	0,026	237,00

## NH Fuse-Links 1000 V / 1500 V TF

For more information  
see page 40

Z



35089-0190

### NH Fuse-Links size 3L, Specialdesign

#### Properties:

- AC 1000 V (425-500 A) and AC 1500 V (6-355 A)
- Breaking capacity: 10 kA
- TF acc. VDE 0660 and DIN 43620/5

Description	Size	Amps	Order-No.	PU	PG	Sur. Ag	Sur. Cu	Price €/pc.
NH-SI 3L 6A TF AC1500V LS	3L	6	<b>35089-0200</b>	1	N 3	0,011	0,026	107,00
NH-SI 3L 10A TF AC1500V LS	3L	10	<b>35089-0010</b>	1	N 3	0,012	0,026	106,00
NH-SI 3L 16A TF AC1500V LS	3L	16	<b>35089-0020</b>	1	N 3	0,014	0,026	106,00
NH-SI 3L 20A TF AC1500V LS	3L	20	<b>35089-0030</b>	1	N 3	0,015	0,026	106,00
NH-SI 3L 25A TF AC1500V LS	3L	25	<b>35089-0040</b>	1	N 3	0,017	0,026	106,00
NH-SI 3L 35A TF AC1500V LS	3L	35	<b>35089-0050</b>	1	N 3	0,017	0,026	106,00
NH-SI 3L 50A TF AC1500V LS	3L	50	<b>35089-0060</b>	1	N 3	0,021	0,026	106,00
NH-SI 3L 63A TF AC1500V LS	3L	63	<b>35089-0070</b>	1	N 3	0,022	0,026	106,00
NH-SI 3L 80A TF AC1500V LS	3L	80	<b>35089-0080</b>	1	N 3	0,028	0,026	106,00
NH-SI 3L 100A TF AC1500V LS	3L	100	<b>35089-0090</b>	1	N 3	0,035	0,026	106,00
NH-SI 3L 125A TF AC1500V LS	3L	125	<b>35089-0100</b>	1	N 3	0,048	0,026	106,00
NH-SI 3L 160A TF AC1500V LS	3L	160	<b>35089-0110</b>	1	N 3	0,069	0,026	113,00
NH-SI 3L 200A TF AC1500V LS	3L	200	<b>35089-0120</b>	1	N 3	0,089	0,026	113,00
NH-SI 3L 224A TF AC1500V LS	3L	224	<b>35089-0130</b>	1	N 3	0,099	0,026	117,00
NH-SI 3L 250A TF AC1500V LS	3L	250	<b>35089-0140</b>	1	N 3	0,110	0,026	117,00
NH-SI 3L 300A TF AC1500V LS	3L	300	<b>35089-0150</b>	1	N 3	0,130	0,026	126,00
NH-SI 3L 315A TF AC1500V LS	3L	315	<b>35089-0160</b>	1	N 3	0,140	0,026	126,00
NH-SI 3L 355A TF AC1500V LS	3L	355	<b>35089-0170</b>	1	N 3	0,150	0,026	126,00
NH-SI 3L 425A TF AC1000V LS	3L	425	<b>35089-0180</b>	1	N 3	0,198	0,026	130,00
NH-SI 3L 500A TF AC1000V LS	3L	500	<b>35089-0190</b>	1	N 3	0,217	0,026	187,00

New trends in energy distribution are showing higher energy density. More and more components (Fuse-Switches, Fuse-Bases) are installed in smaller cabinets. Cabinets have a limited power acceptance and the space for installation is an important part of the total costs. The main application in energy distribution grids is the 230/400 V voltage range.

EFEN 400 V fuses with lower power dissipation are perfectly fitting to the needs of the actual applications and are also saving energy. The twin Indicator guarantees clear visibility of the fuse status in different installations.

- Energy saving construction with 400 V melting element
- Reduced power dissipation and temperature rise
- Twin Indicator assures optimal visibility in different applications

**Comparison of power dissipation 400 V and 500 V NH Fuse-Link**

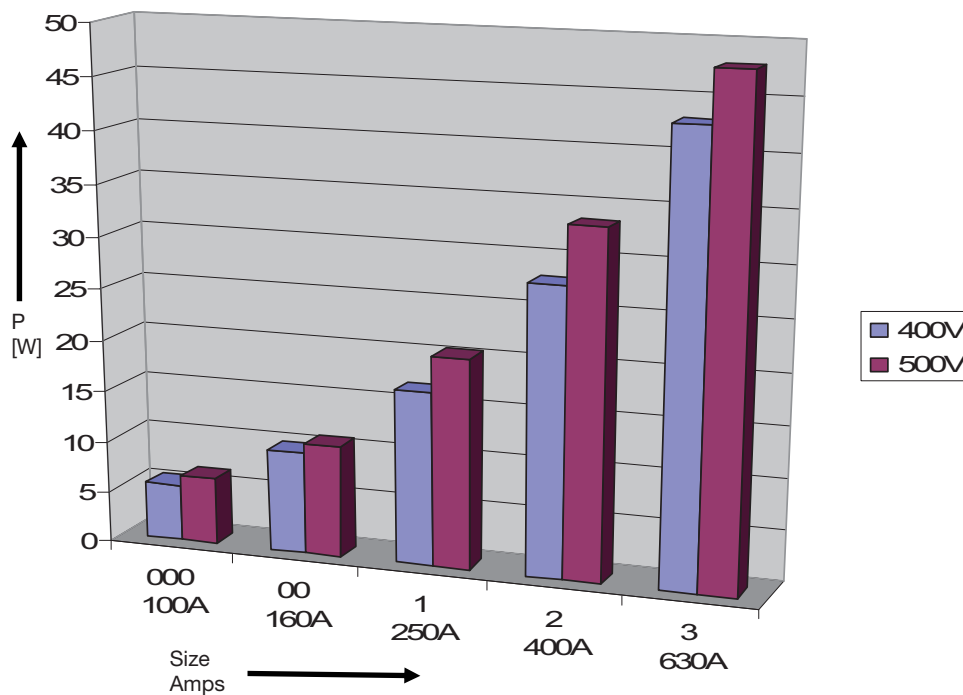

**Saved Energy per year and fuse-link\***

Size current	E [kWh]
NH 000 100A	2,6
NH 00 160A	2,9
NH 1 250A	9,2
NH 2 400A	14,5
NH 3 630A	13,1

\* 80% I<sub>n</sub> / ½time

Size	Amps	Live metal gripping lugs Order no.	Dead metal gripping lugs Order no.	Pack
000	2	35401-0020	35406-0020	3
000	4	35401-0040	35406-0040	3
000	6	35401-0060	35406-0060	3
000	10	35401-0100	35406-0100	3
000	16	35401-0160	35406-0160	9
000	20	35401-0200	35406-0200	9
000	25	35401-0250	35406-0250	9
000	32	35401-0320	35406-0320	9
000	35	35401-0350	35406-0350	9
000	40	35401-0400	35406-0400	9
000	50	35401-0500	35406-0500	9
000	63	35401-0630	35406-0630	9
000	80	35401-0800	35406-0800	9
000	100	35401-1000	35406-1000	9
00	125	35402-1250	35407-1250	3
00	160	35402-1600	35407-1600	3
1	16	35403-0160	35408-0160	3
1	20	35403-0200	35408-0200	3
1	25	35403-0250	35408-0250	3
1	32	35403-0320	35408-0320	3
1	35	35403-0350	35408-0350	3
1	40	35403-0400	35408-0400	3
1	50	35403-0500	35408-0500	3
1	63	35403-0630	35408-0630	3
1	80	35403-0800	35408-0800	3
1	100	35403-1000	35408-1000	3
1	125	35403-1250	35408-1250	3
1	160	35403-1600	35408-1600	3
1	200	35403-2000	35408-2000	3
1	224	35403-2240	35408-2240	3
1	250	35403-2500	35408-2500	3
2	35	35404-0350	35409-0350	3
2	50	35404-0500	35409-0500	3
2	63	35404-0630	35409-0630	3
2	80	35404-0800	35409-0800	3
2	100	35404-1000	35409-1000	3
2	125	35404-1250	35409-1250	3
2	160	35404-1600	35409-1600	3
2	200	35404-2000	35409-2000	3
2	224	35404-2240	35409-2240	3
2	250	35404-2500	35409-2500	3
2	300	35404-3000	35409-3000	3
2	315	35404-3150	35409-3150	3
2	355	35404-3550	35409-3550	3
2	400	35404-4000	35409-4000	3
3	250	35405-2500	35410-2500	1
3	300	35405-3000	35410-3000	1
3	315	35405-3150	35410-3150	1
3	400	35405-4000	35410-4000	1
3	425	35405-4250	35410-4250	1
3	500	35405-5000	35410-5000	1
3	630	35405-6300	35410-6300	1

For cable and line protection  
 Rated voltage: AC 400 V  
 Utilization category:  
 gG acc. VDE 0636-2 / IEC 60269-2  
 Application: for cable and line protection  
 Breaking capacity: 100 kA

Z

Time-current characteristics for NH Fuse-Links size 000 - 3 gG AC 400 V VDE 0636 T 2 / IEC 60269-2

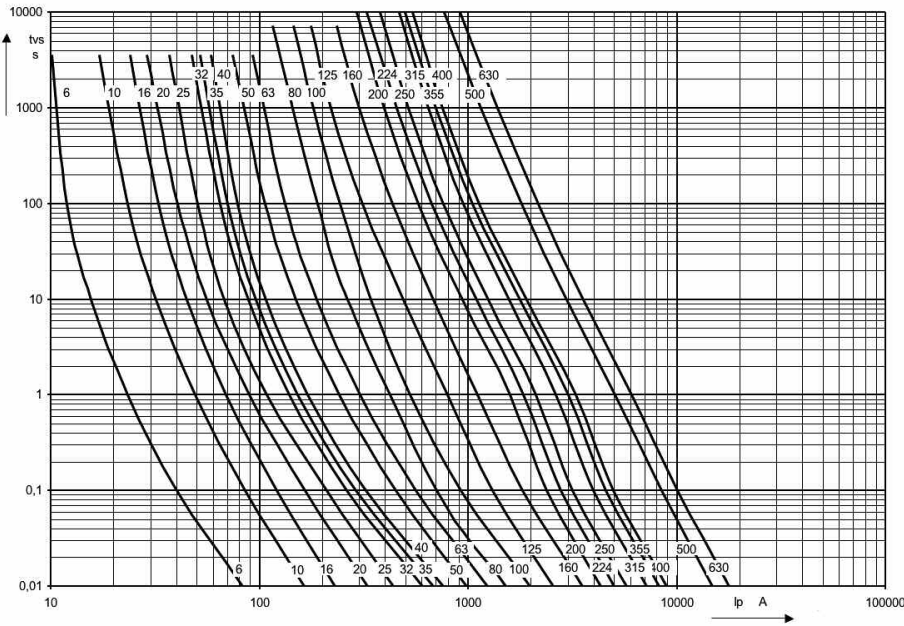

Cut-off current characteristics for NH Fuse-Links size 000 - 3 gG AC 400 V VDE 0636 T 2 / IEC 60269-2

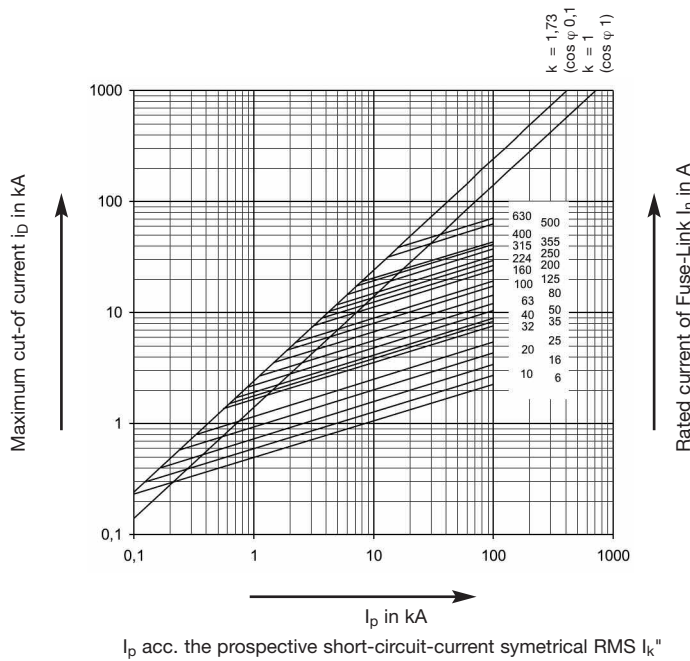

## Power dissipation in W for NH Fuse-Links size 000 - 3 gG AC 400 V VDE 0636 Teil 2 IEC 60 269-2

I <sub>n</sub> A	Size				
	000	00	1	2	3
6	1,7				
10	1,0				
16	1,8				
20	2,0				
25	2,4				
32	2,6				
35	3,2				
40	3,1				
50	3,5		4,5		
63	4,5	4,5	5,7		
80	5,0	5,0	5,5		
100	5,5	5,5	7,0	7,3	
125		8,6	9,1	9,1	
160		9,6	13,0	13,0	
200			13,1	13,5	
224			15,1	15,1	
250			16,9	18,0	
315				19,9	22,7
355				22,7	28,0
400				28,0	
500					30,8
630					43,0

Z

## Pre-arcing and operating integrals acc. gG AC 400 V VDE 0636 Teil 2 IEC 60 269-2

I <sub>n</sub> A	Size									
	000		00		1		2		3	
	Pre-arcing integrals	Operating integrals	Pre-arcing integrals	Operating integrals	Pre-arcing integrals	Operating integrals	Pre-arcing integrals	Operating integrals	Pre-arcing integrals	Operating integrals
6	53	160								
10	115	570								
16	220	1 150								
20	455	2 400								
25	880	3 700								
32	2 450	9 000								
35	3 150	11 500			3 150	11 500	3 150	11 500		
40	3 950	14 000			3 950	14 000	-	-		
50	6 450	22 500			6 450	22 500	6 450	22 500		
63	9 950	35 500	9 950	35 500	9 950	35 500	9 950	35 500		
80	16 950	59 500	16 950	59 500	16 950	59 500	16 950	59 500		
100	28 500	100 300	28 500	100 300	28 500	100 300	28 500	100 300		
125			38 500	139 500	38 500	139 500	38 500	139 500		
160			76 500	279 000	76 500	279 000	76 500	279 000		
200					126 000	458 000	126 000	458 000		
224					171 000	610 000	171 000	610 000		
250					224 000	797 000	224 000	797 000	224 000	797 000
315							353 000	1 221 000	353 000	1 221 000
355							464 000	1 617 000	-	-
400							552 000	1 924 000	552 000	1 924 000
500									1 672 000	4 672 000
630									2 381 000	6 837 000



Dimensions DIN 436201

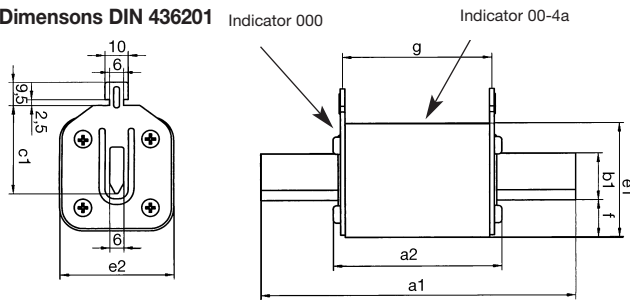

For cable and line protection

Rated voltage: AC 500 V/DC 440 V\*

Utilization category: gG acc. VDE 0636-2 + VDE 0636-1  
IEC 60 269-1 IEC 60 269-2

Application: for cable and line protection

Breaking capacity: 120 kA (AC 500 V) /25 kA (DC 440 V)

\*Size 00 DC 220 V

Size	Rated current	a <sub>1</sub>	a <sub>2</sub>	b <sub>1</sub>	c <sub>1</sub>	e <sub>1</sub>	e <sub>2</sub>	g
000		78,5	53	15	35	40	21	47
00	up to 160 A	78,5	53	15	35	47	30	47
1	up to 160 A	135	71	15	40	47	30	65
1	200-250 A	135	71	20	40	52	40	65
2	up to 250 A	150	72	20	48	52	40	65
2	300-400 A	150	72	26	48	60	51	65
3	up to 400 A	150	72	26	60	60	51	65
3	500-630 A	150	72	33	60	74	70	65
4a		200	96	50	85	109	98	86

Electrical characteristics:

The time-current characteristics are matched to the line and cable capacities. The line to be protected can operate at optimal load since breaking in the overload range is slow and quick in case of a short circuit current.

The time-current zones acc. to IEC 60 269 guarantee selectivity between Fuse-Links of different manufacturers made acc. to this standard. Selective short-circuit interruption is given at rated currents  $I_N \geq 16$  A having rated current ratios of 1:1,6.

Size	Amps	Live metal gripping lugs Order no.	Amps	Dead gripping lugs of special polymer Order no.	Amps	Dead metal gripping lugs Order no.	Pack
000	2	35000-0020	2	35001-0020			10
000	4	35000-0040	4	35001-0040			10
000	6	35000-0060	6	35001-0060			10
000	10	35000-0100	10	35001-0100			10
000	16	35000-0160	16	35001-0160			10
000	20	35000-0200	20	35001-0200			10
000	25	35000-0250	25	35001-0250			10
000	32	35000-0320	32	35001-0320			10
000	35	35000-0350	35	35001-0350			10
000	40	35000-0400	40	35001-0400			10
000	50	35000-0500	50	35001-0500			10
000	63	35000-0630	63	35001-0630			10
000	80	35000-0800	80	35001-0800			10
000	100	35000-1000	100	35001-1000			10
00	2	35011-0010			2	35165-0010	3
00	4	35011-0020			4	35165-0020	3
00	6	35011-0030			6	35165-0030	3
00	10	35011-0040			10	35165-0040	3
00	16	35011-0050			16	35165-0050	3
00	20	35011-0060			20	35165-0060	3
00	25	35011-0070			25	35165-0070	3
00	32	35011-0080			32	35165-0080	3
00	35	35011-0090			35	35165-0090	3
00	40	35011-0100			40	35165-0100	3
00	50	35011-0110			50	35165-0110	3
00	63	35011-0120			63	35165-0120	3
00	80	35011-0130			80	35165-0130	3
00	100	35011-0140			100	35165-0140	3
00	125	35011-0150			125	35165-0150	3
00	160	35011-1090			160	35165-0160	3
1	25	35035-0050			25	35204-0050	3
1	32	35035-1220			32	35204-0160	3
1	35	35035-0060			35	35204-0060	3
1	40	35035-1230			40	35204-0170	3
1	50	35035-0070			50	35204-0070	3
1	63	35035-0080			63	35204-0080	3
1	80	35035-0090			80	35204-0090	3
1	100	35035-0100			100	35204-0110	3
1	125	35035-0110			125	35204-0110	3
1	160	35035-0120			160	35204-0120	3
1	200	35035-0130			200	35204-0130	3
1	224	35035-0140			224	35204-0140	3
1	250	35035-0150			250	35204-0150	3

Size	Amps	Live metal gripping lugs Order no.	Amps	Dead gripping lugs of special polymer Order no.	Pack
2	25	35054-0010			3
2	35	35054-0020			3
2	50	35054-0030			3
2	63	35054-0040	63	35116-0040	3
2	80	35054-0050	80	35116-0050	3
2	100	35054-0060	100	35116-0060	3
2	125	35054-0070	125	35116-0070	3
2	160	35054-0080	160	35116-0080	3
2	200	35054-0090	200	35116-0090	3
2	224	35054-0100	224	35116-0100	3
2	250	35054-0110	250	35116-0110	3
2	(300)	35054-0120	(300)	35116-0120	3
2	315	35054-0130	315	35116-0130	3
2	(355)	35054-0140	(355)	35116-0140	3
2	400	35054-0150	400	35116-0150	3
3	63	35078-0340	100	35420-1000	3
3	80	35078-0350	125	35420-1250	3
3	100	35078-0360	160	35420-1600	3
3	125	35078-0370	200	35420-2000	3
3	160	35078-0380	224	35420-2240	3
3	200	35078-0390	250	35420-2500	3
3	224	35078-0400	300	35420-3000	3
3	250	35078-0410	315	35420-3150	3
3	(300)	35078-0190	355	35420-3550	3
3	315	35078-0010	400	35420-4000	3
3	(355)	35078-0020	425	35420-4250	3
3	400	35078-0030	425	35420-5000	3
3	(425)	35078-0040	630	35420-6300	3
3	500	35078-0050			3
3	630	35078-0060			3
4a	400	35097-0120			1
4a	500	35097-0010			1
4a	630	35097-0020			1
4a	800	35097-0030			1
4a	1000	35097-0040			1
4a	1250	35097-0050			1
4a	1600	35097-0110			1

Z

( ) = Dimensions according DIN, rating not standardized in VDE 0636.

Force - Distance-Diagram of the striker

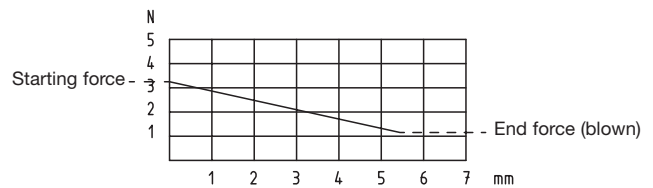

**NH Fuse-Links size 00 with striker pin**

EFEN NH Fuse-Links size 00 with striker pin can be used for fuse monitoring, tripping on micro switch.

**NH Fuse-Links for cable and line protection size 00, 500 V AC, category gL, with striker pin**

Amps	Order no.	Description
6	35207-0010	NH-Si 00 6A gL SM
10	35207-0020	NH-Si 00 10A gL SM
16	35207-0030	NH-Si 00 16A gL SM
20	35207-0040	NH-Si 00 20A gL SM
25	35207-0050	NH-Si 00 25A gL SM
32	35207-0060	NH-Si 00 32A gL SM
35	35207-0070	NH-Si 00 35A gL SM
40	35207-0080	NH-Si 00 40A gL SM
50	35207-0090	NH-Si 00 50A gL SM
63	35207-0100	NH-Si 00 63A gL SM
80	35207-0110	NH-Si 00 80A gL SM
100	35207-0120	NH-Si 00 100A gL SM
125	35207-0130	NH-Si 00 125A gL SM

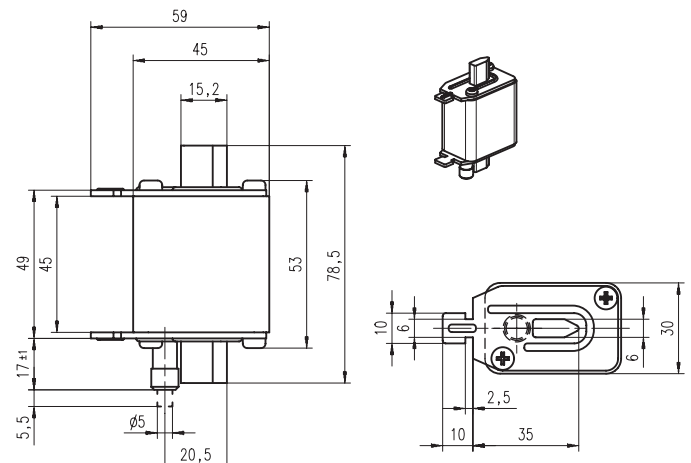

**Time-current characteristics for NH Fuse-Links size 000 gG AC 500 V VDE 0636 T 2 / IEC 60269-2**

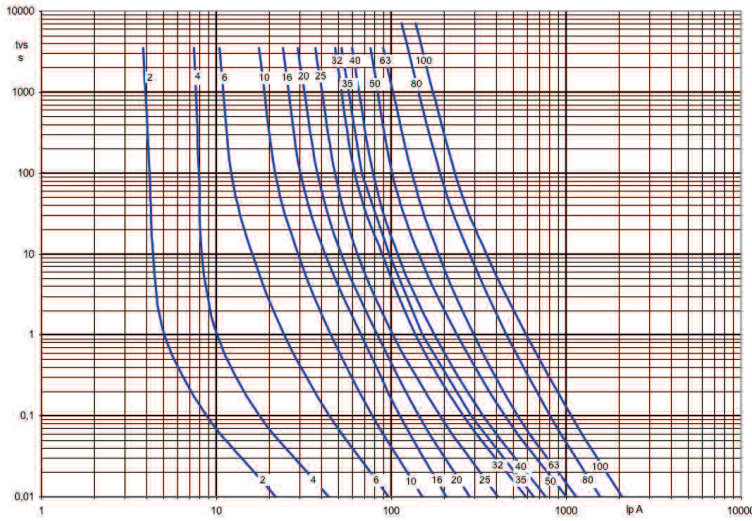

**Time-current characteristics for NH Fuse-Links size 00-4a gG AC 500 V VDE 0636 T 2 / IEC 60269-2**

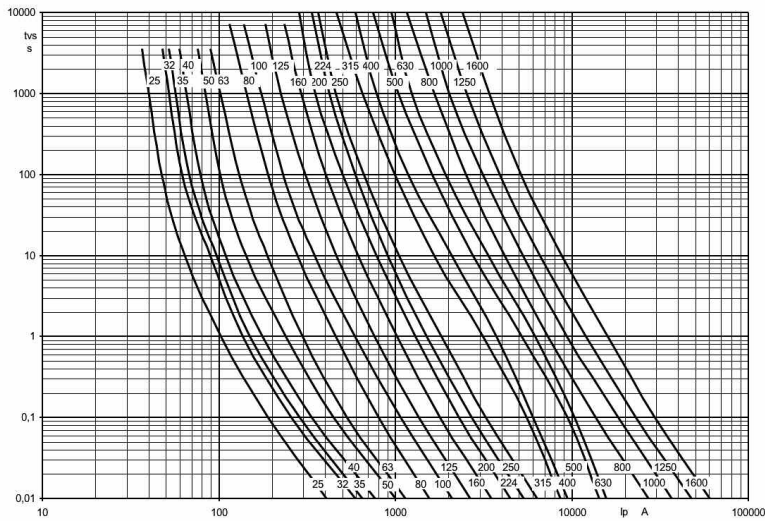

**Cut-off current characteristics for NH Fuse-Links size 000 - 3 gG AC 500 V VDE 0636 T 2 / IEC 60269-2**

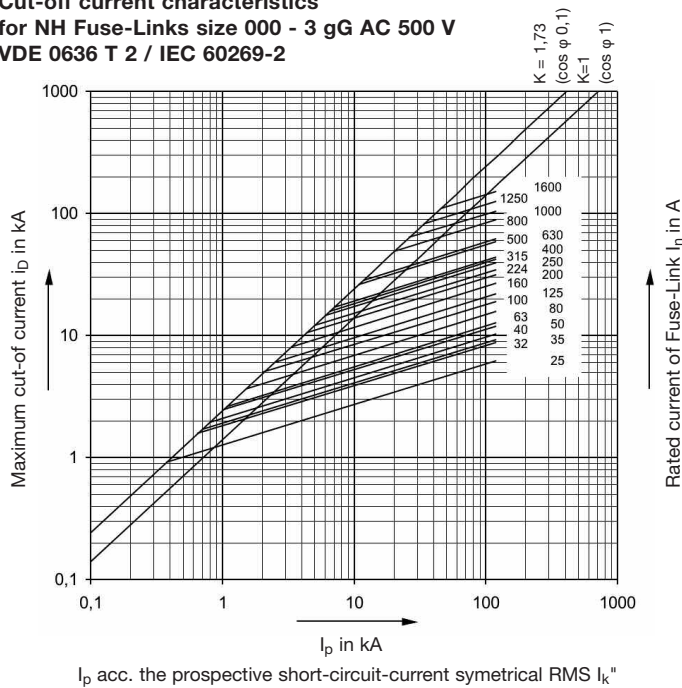

For cable and line protection. Power dissipation in W acc. VDE 0636-2; IEC/EN 60269-2

I <sub>n</sub> A	Size					
	000	00	1	2	3	4a
6	1,6					
10	1,1					
16	1,8		1,8			
20	2,3		2,3			
25	2,4	2,4	2,4			
32	3,1	3,1	3,1			
35	3,0	3,0	3,0			
40	3,7	3,7	3,7			
50	4,1	4,1	4,1	4,1		
63	5,4	5,6	6,6	6,8		
80	6,5	6,8	8,0	8,3		
100	7,5	7,5	9,4	10,7		
125		10,0	11,8	12,2		
160		12,0	14,6	15,0		
200			18,0	18,5		
224			19,0	19,2	20,0	
250			20,0	20,6	21,1	
315				25,0	25,0	
355				31,5	32,0	
400				28,5	34,0	31,2
500					43,0	36,5
630					43,1	44,4
800						68,0
1000						72,9
1250						100,5
1600						126,2

Z

Pre-arcing integrals and operating integrals acc. VDE/IEC in A<sup>2</sup>s acc. VDE 0636-2; IEC/EN 60269-2

I <sub>n</sub> A	Size											
	000		00		1		2		3		4a	
	Pre-arcing integrals	Operating integrals	Pre-arcing integrals	Operating integrals	Pre-arcing integrals	Operating integrals	Pre-arcing integrals	Operating integrals	Pre-arcing integrals	Operating integrals	Pre-arcing integrals	Operating integrals
6	53,6	280										
10	109	490										
16	199	890										
20	430	1930										
25	890	4010	890	4010	990	4010	990	4010				
32	2475	6900	2475	6900	2475	6900	2475	6900				
35	2990	8380	2990	8380	2990	8380	2990	8380				
40	3970	10100	3970	10100	3970	10100	3970	10100				
50	6330	16150	6330	16150	6330	16150	6330	16150				
63	7430	20800	7430	20800	7430	20800	7430	20800	7430	20800		
80	14250	39900	14250	39900	14250	39900	14250	39900	14250	39900		
100	25340	70900	25340	70900	25340	71000	25340	71000	25340	71000		
125			39600	110800	39600	111000	39600	111000	39600	111000		
160			70400	197100	70400	197100	70400	197100	70400	197100		
200					114400	320000	114400	320000	114400	320000		
224					158400	444000	158400	444000	158400	444000		
250					228000	639000	228000	639000	228000	639000		
315							275900	773000	275900	773000		
355							356400	998000	356400	998000		
400							431200	1207000	431200	1207000	610500	927000
500									766600	2147000	1025 10 <sup>3</sup>	1618 10 <sup>3</sup>
630									912300	3013000	1767 10 <sup>3</sup>	2600 10 <sup>3</sup>
800											3499 10 <sup>3</sup>	5449 10 <sup>3</sup>
1000											5878 10 <sup>3</sup>	8708 10 <sup>3</sup>
1250											12164 10 <sup>3</sup>	18676 10 <sup>3</sup>
1600											20347 10 <sup>3</sup>	31278 10 <sup>3</sup>

**For cable and line protection in meshed networks**

(Resistant to aging)

Rated voltage: AC 500 V

 Utilization category: gL - gG acc. VDE 0636/21  
IEC 269-2

Application: for cable and line protection

Breaking capacity: 120 kA (Gr. 00-2)

**Electrical characteristics**

The time-current characteristics are matched to the line and cable capacities. The lines to be protected can operate at optimal load since breaking in the overload range is slow and quick in case of a short circuit current.

The time-current zones acc. to IEC 269-2 guarantee selectivity between Fuse-Links of different manufacturers made acc. to this standard. Selective short-circuit interruption is given at rated current  $I_N \geq 16$  A having rated current ratios of 1:1,6. EFEN-500 V-Fuse-Links, when used in 400 V-AC-systems match a discrimination ratio of 1:1,25, i.e. discrimination between all Fuse-Links having different rated current.

EFEN Pure silver fuse-elements are specifically suited for use in meshed distribution systems. Fuse-links rated at 500 V show a discrimination factor of 0,79 when used in 400 V-systems, i.e. if the maximum partial current does not exceed 79 % of the total short-circuit current the fuse-link closest to the failure only will operate. Due to aging resistant pure silver fuse elements a proper discrimination is ensured over a long life-time.

Remark: Standard blown fuse indicators do not necessarily work at low differential voltage as given in meshed systems. Please ask for special EFEN-solution.

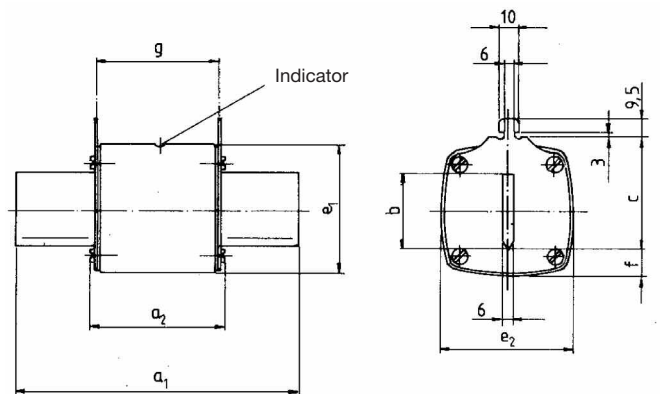
**Dimensions: DIN 43620/1**

Size	a <sub>1</sub>	a <sub>2</sub>	b	c	e <sub>1</sub>	e <sub>2</sub>	f	g
00 <sup>1)</sup>	78,5	53	15	35	40	28	12,5	47
0	125	67	15	35	38	35	11,5	65
1 <sup>2)</sup>	135	74	20	40	38	35	9	65
1 <sup>3)</sup>	135	74	24,5	40	45	45	10	65
2 <sup>4)</sup>	150	74	25	48	45	45	10	65
2 <sup>5)</sup>	150	72	30	48	59	59	14,5	65
3 <sup>6)</sup>	150	72	40	60	70	70	15	65

- 1) Rated current up to 160 A
- 2) Rated current up to 125 A
- 3) Rated current 160-250 A
- 4) Rated current up to 250 A
- 5) Rated current 300-400 A
- 6) Rated current up to 630 A



Time-current characteristics acc. VDE 0636-2; IEC/EN 60269-2

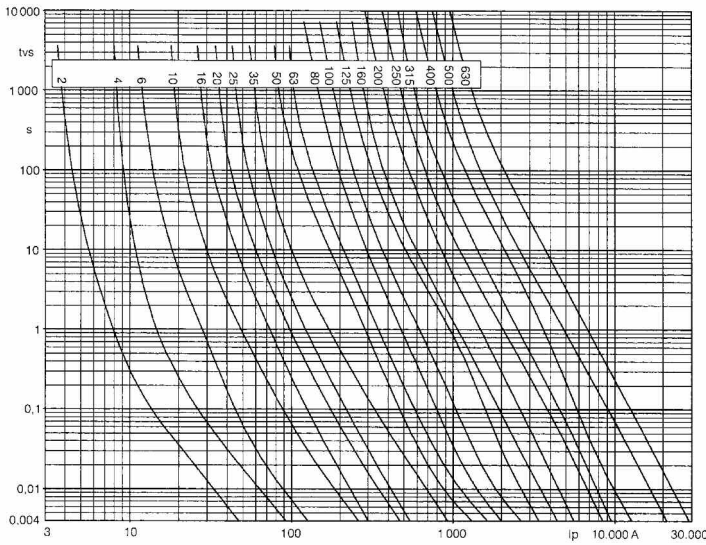

Cut-off-current characteristics acc. VDE 0636-2; IEC/EN 60269-2

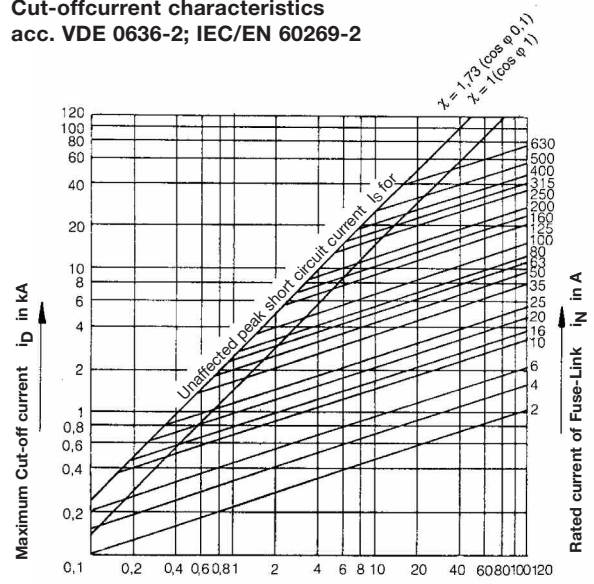

Prospective Short-Circuit-Current symmetrical RMS

Power dissipation in W acc. VDE 0636-2; IEC/EN 60269-2

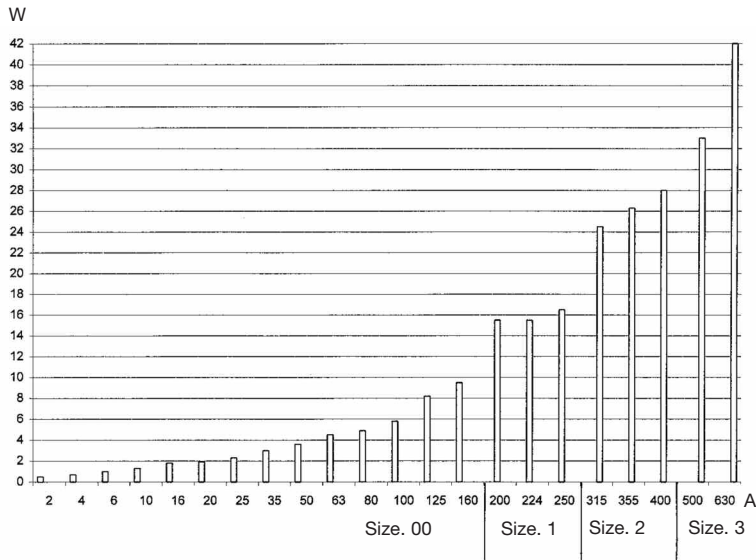

Pre-arcing and operating integrals acc. VDE 0636-2; IEC/EN 60269-2

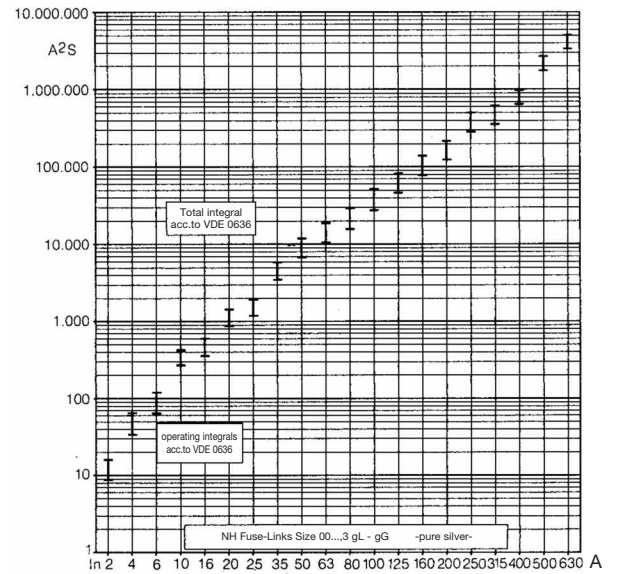



**For cable and line protection**

Rated voltage: AC 690 V

 Utilization category: gG acc. VDE 0636-2 + VDE 0636-1  
 IEC 60 269-2 IEC 60 269-1

Application: for cable and line protection

Breaking capacity: 100 kA (630 A 50 kA)

**Electrical characteristics:**

The time-current characteristics are matched to the line and cable capacities. The lines to be protected can operate at optimal load since breaking in the overload range is slow and quick in case of a short circuit current.

Size	Amps	metal gripping lugs Order no.	Pack
00	2	35421-0020	10
00	4	35421-0040	10
00	6	35421-0060	10
00	10	35421-0100	10
00	16	35421-0160	10
00	20	35421-0200	10
00	25	35421-0250	10
00	32	35421-0320	10
00	35	35421-0350	10
00	40	35421-0400	10
00	50	35421-0500	10
00	63	35421-0630	10
00	80	35422-0800	10
00	100	35422-1000	10
1	25	35422-1250	3
1	32	35423-0250	3
1	35	35423-0320	3
1	40	35423-0350	3
1	50	35423-0400	3
1	63	35423-0500	3
1	80	35423-0630	3
1	100	35423-0800	3
1	125	35423-1000	3
1	160	35423-1250	3
1	200	35423-1600	3
1	(250)	35423-2000	3
2	25	35423-2500	3
2	35	35424-0250	3
2	50	35424-0350	3
2	63	35424-0500	3
2	80	35424-0630	3
2	100	35424-0800	3
2	125	35424-1000	3
2	160	35424-1250	3
2	200	35424-1600	3
2	250	35424-2000	3
2	315	35424-2500	3
2	(355)	35424-3150	3
2	(400)	35424-3550	3
3	63	35424-4000	3
3	80	35425-0800	3
3	100	35425-1000	3
3	125	35425-1250	3
3	160	35425-1600	3
3	200	35425-2000	3
3	224	35425-2240	3
3	250	35425-2500	3
3	315	35425-3150	3
3	(355)	35425-3550	3
3	400	35425-4000	3
3	500	35425-4250	3
3	(630)	35425-5000	3

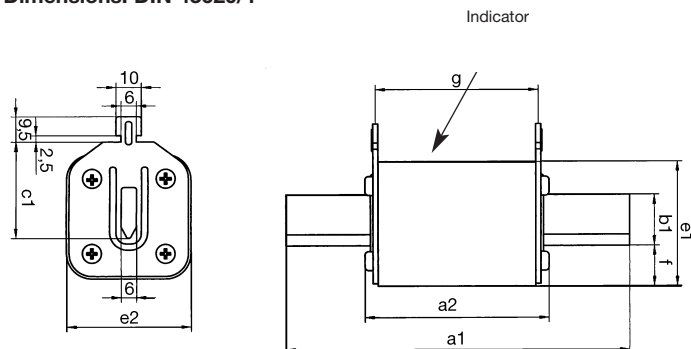
**Dimensions: DIN 43620/1**

Size	Rated current	a <sub>1</sub>	a <sub>2</sub>	b <sub>1</sub>	c <sub>1</sub>	e <sub>1</sub>	e <sub>2</sub>	g
000	6-63 A	78,5	53	15	35	37	21	47
00	80-100 A	78,5	53	15	35	45	30	47
1	25-160 A	135	70	15	40	45	30	65
1	200-250 A	135	70	20	40	50	50	65
2	25-250 A	150	71	20	48	50	50	65
2	315-400 A	150	71	26	48	58	58	65
3	63-400 A	150	71	26	60	58	58	65
3	500 A, 630 A	150	74	32	60	71	71	65

( ) = Dimensions according DIN, rating not standardized in VDE 0636.

For cable and line protection

Time-current characteristics acc. VDE 0636-2; IEC/EN 60269-2

Z

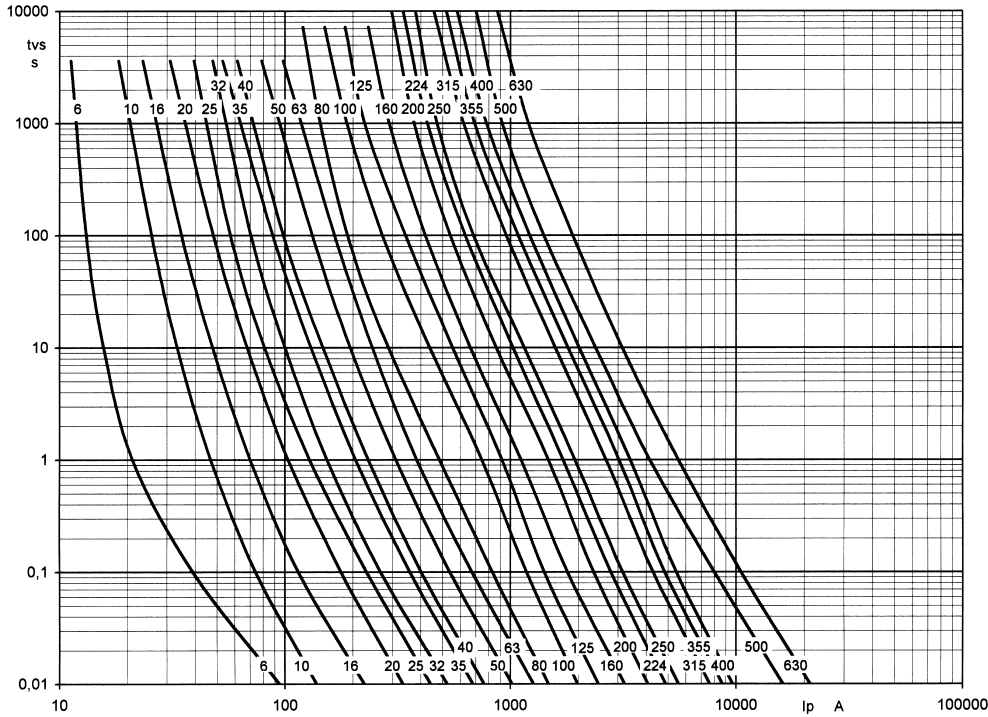

Cut-off current characteristics acc. VDE 0636-2; IEC/EN 60269-2

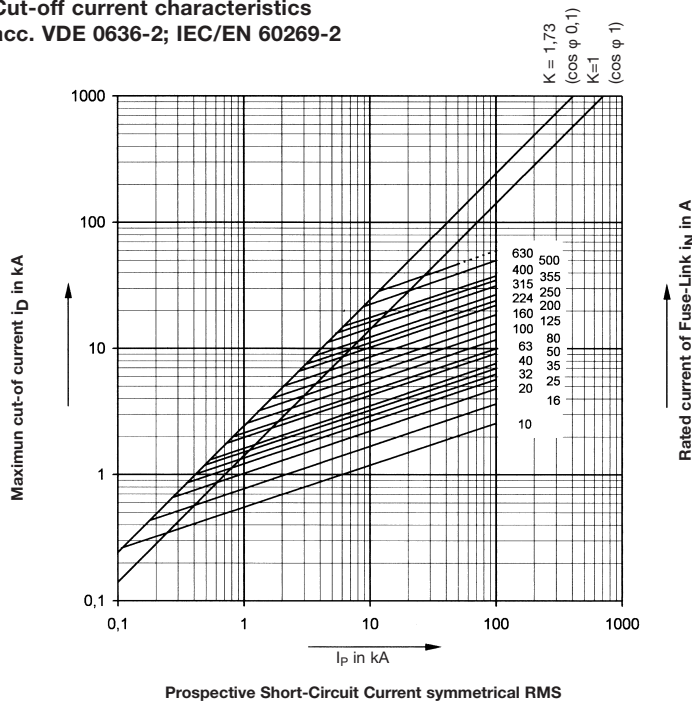

**For transformer protection**

Rated voltage: AC 400 V

Utilization category: gTr acc. VDE 0636/2011

Application: for transformer protection

Breaking capacity: 100 kA

Size	Amps	kVA	metal gripping lugs Order no.	Pack
2	(72)	50	35076-1010	3
2	(108)	75	35076-1020	3
2	(144)	100	35076-1030	3
2	(180)	125	35076-1040	3
2	(231)	160	35076-1050	3
2	(289)	200	35076-1060	3
2	(361)	250	35076-1070	3
3	(144)	100	35081-1040	1
3	(231)	160	35081-1060	1
3	(289)	200	35081-1050	1
3	(361)	250	35081-1010	1
3	(455)	315	35081-1020	1
3	(577)	400	35081-1030	1
3	(722)	500	35081-0100	1
3	(909)	630	35081-0110	1
4a	(144)	100	35100-0100	1
4a	(231)	160	35100-0110	1
4a	(289)	200	35100-0160	1
4a	(361)	250	35100-0120	1
4a	(455)	315	35100-0170	1
4a	(577)	400	35100-0130	1
4a	(722)	500	35100-0140	1
4a	(909)	630	35100-0150	1
4a	(1155)	800	35100-0040	1
4a	(1443)	1000	35100-0190	1

**Electrical characteristics:**

The time-current characteristics are adapted to the thermal capacity of the transformer and the time-current characteristics of the high-voltage Fuse-Links. Therefore a better utilization of the overload capacity of transformers. EFEN transformer Fuse-Links are able to carry 1,3-times current rated of a transformer as continuous load for a minimum of 10 hrs. Fuse operates within 2 hrs at 1,5-times rated current of the transformer.

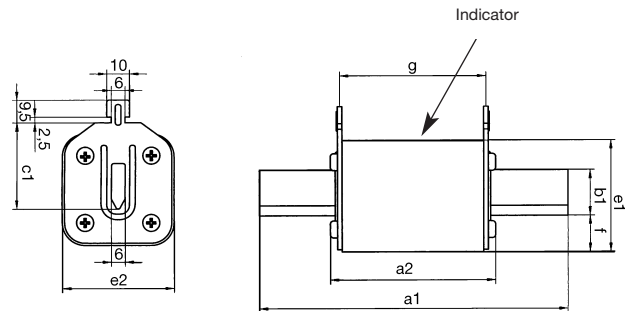
**Dimensions: DIN 43620/1**

Size	a <sub>1</sub>	a <sub>2</sub>	b	c	e <sub>1</sub>	e <sub>2</sub>	f	g
2	150	72	26	48	60	53	14	65
3	150	72	32	60	70	65	14	65
3 <sup>1)</sup>	150	74	32	60	71	71	14	65
4a	200	98	50	85	110	102	28	87

1) 500 kVA and 630 kVa

( ) = Dimensions according DIN, rating not standardized in VDE 0636.

For transformer protection

Time-current characteristics acc. VDE 0636-2; IEC/EN 60269-2

Z

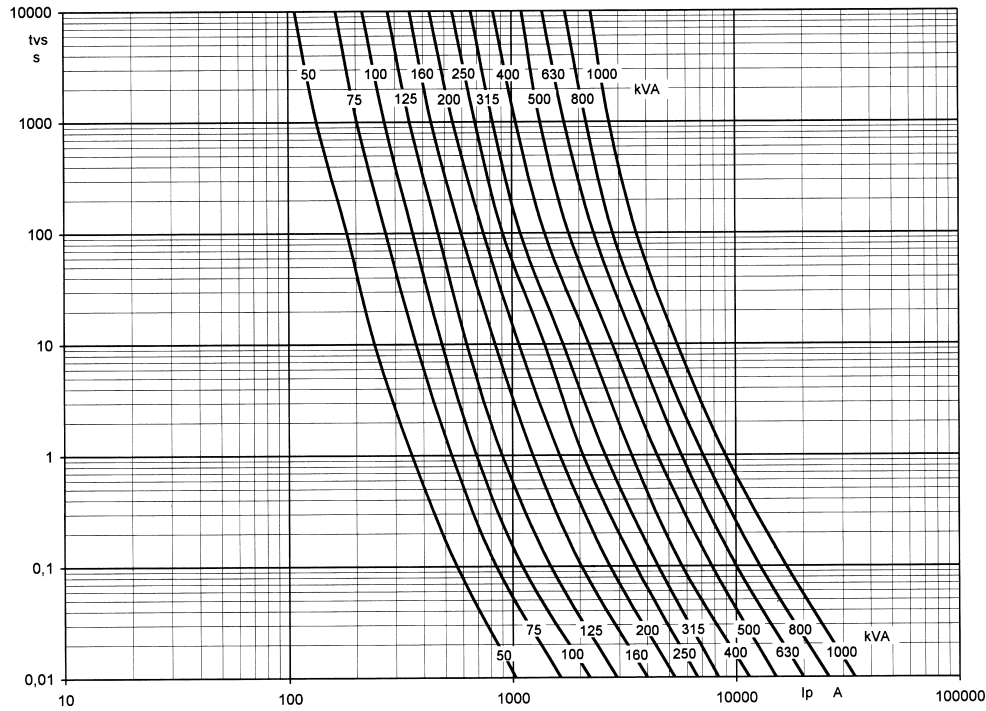

Cut-off current characteristics acc. VDE 0636-2; IEC/EN 60269-2

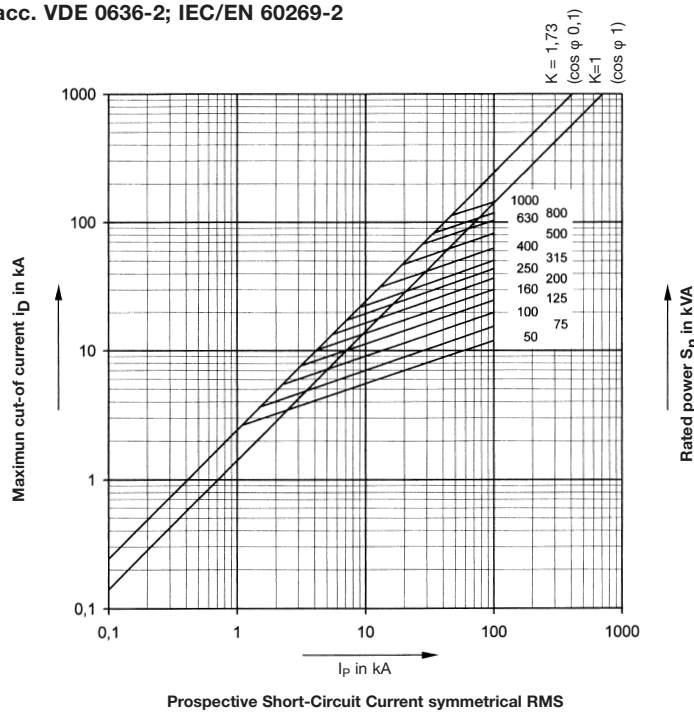

**For protection of semiconductors – Pure silver fuse element**

Rated voltage: AC 500 V

Utilization category: gR acc. VDE 0636-4

Application: for protection of semiconductors

Breaking capacity: 120 kA

**Electrical characteristics:**

EFEN-NH-Fuse-Links for the protection of semiconductors have the following specific properties:

1. a super fast acting time-current characteristic
2. low arcing voltage

EFEN-gR-Fuse-Links offer full-range protection. They may be used as full-range fuses for overload and short circuit-protection or in connection with other overcurrent protective devices as short-circuit protection only.

**Version with striker:**

Parallel to the Fuse-Links a spring-loaded striker pin is mounted. After the melting of the NH Fuse element pin is released and operates a micro-switch on the NH Fuse-base.

**without striker**

Size	Amps	metal gripping lugs Order no.	Pack
00	16	35024-0180	10
00	20	35024-0170	10
00	25	35024-0190	10
00	35	35024-0010	10
00	40	35024-0020	10
00	50	35024-0030	10
00	63	35024-0040	10
00	80	35024-0050	10
00	100	35024-0060	10
00	125	35024-0070	10
00	160	35024-0080	10
1	35	35040-0010	3
1	50	35040-0020	3
1	63	35040-0030	3
1	80	35040-0040	3
1	100	35040-0050	3
1	125	35040-0060	3
1	160	35040-0070	3
1	200	35040-0080	3
1	(224)	35040-0090	3
1	250	35040-0100	3
2	80	35058-0010	3
2	100	35058-0020	3
2	125	35058-0030	3
2	160	35058-0040	3
2	200	35058-0050	3
2	(224)	35058-0060	3
2	250	35058-0070	3
2	(300)	35058-0080	3
2	315	35058-0090	3
2	(355)	35058-0100	3
2	400	35058-0110	3
3	315	35079-0010	1
3	(355)	35079-0020	1
3	400	35079-0030	1
3	(425)	35079-0040	1
3	500	35079-0050	1
3	630	35079-0060	1

( ) = Dimensions according DIN, rating not standardized in VDE 0636.

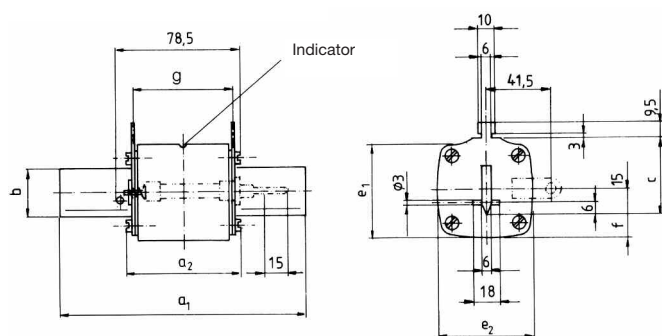
**Dimensions: DIN 43620/1**

**with striker**

Size	Amps	metal gripping lugs Order no.	Pack
00	16	35218-0010	10
00	20	35218-0020	10
00	25	35218-0030	10
00	35	35218-0040	10
00	40	35218-0050	10
00	50	35218-0060	10
00	63	35218-0070	10
00	80	35218-0080	10
00	100	35218-0090	10
00	125	35218-0100	10
1	35	35046-0010	1
1	50	35046-0020	1
1	63	35046-0030	1
1	80	35046-0040	1
1	100	35046-0050	1
1	125	35046-0060	1
1	160	35046-0070	1
1	200	35046-0080	1
1	(224)	35046-0090	1
1	250	35046-0100	1
2	80	35060-0050	1
2	100	35060-0060	1
2	125	35060-0070	1
2	160	35060-0080	1
2	200	35060-0090	1
2	(224)	35060-0100	1
2	250	35060-0110	1
2	(300)	35060-0120	1
2	(315)	35060-0130	1
2	355	35060-0140	1
2	400	35060-0150	1
3	315	35086-0010	1
3	(355)	35086-0020	1
3	400	35086-0030	1
3	(425)	35086-0040	1
3	500	35086-0050	1
3	630	35086-0060	1

Size	a <sub>1</sub>	a <sub>2</sub>	b	c	e <sub>1</sub>	e <sub>2</sub>	f	g
00	78,5	53	15	35	40	28	12,5	47
0	125	67	15	35	38	35	11,5	65
1	135	71	24,5	40	45	45	10	65
2	150	72	30	48	59	59	14,5	65
3	150	72	40	60	70	70	15	65



For protection of semiconductors – Pure silver fuse element

Time-current characteristics acc. VDE 0636-2; IEC/EN 60269-2

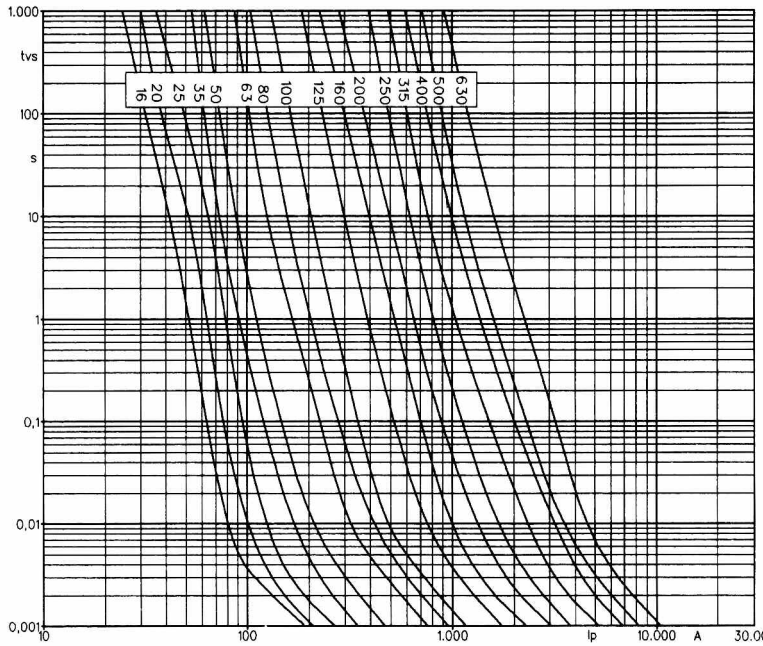

Force - Distance-Diagram of the striker

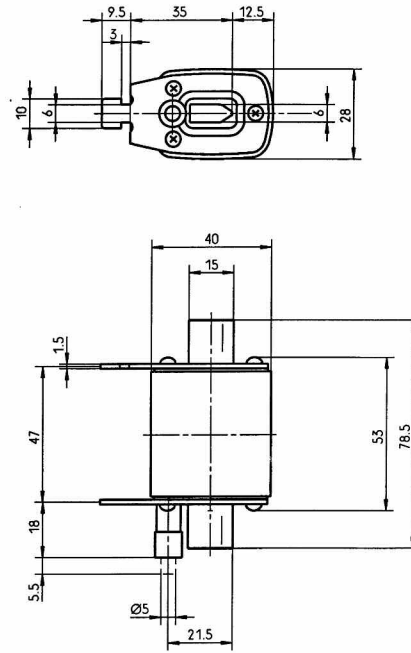
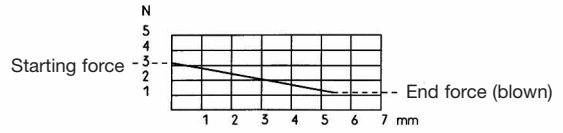

Cut-off-current characteristics acc. VDE 0636-2; IEC/EN 60269-2

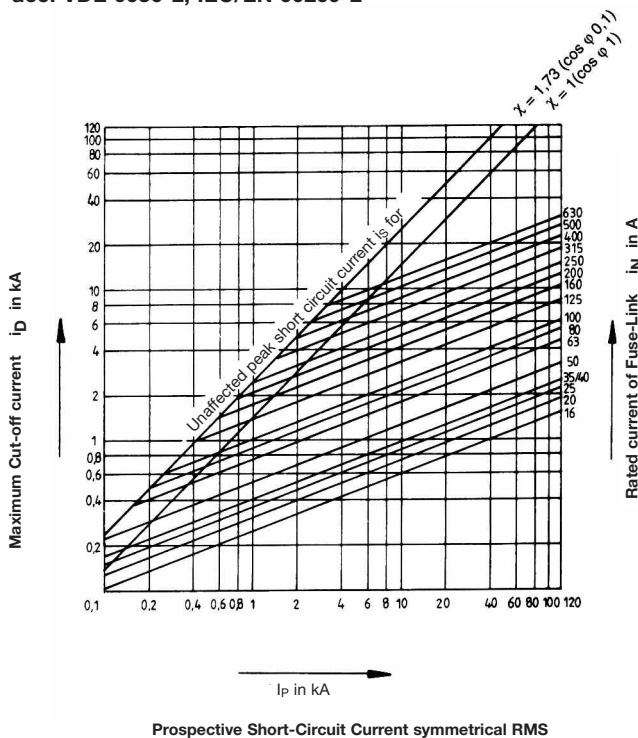

Pre-arcing and operating integrals acc. VDE 0636-2; IEC/EN 60269-2

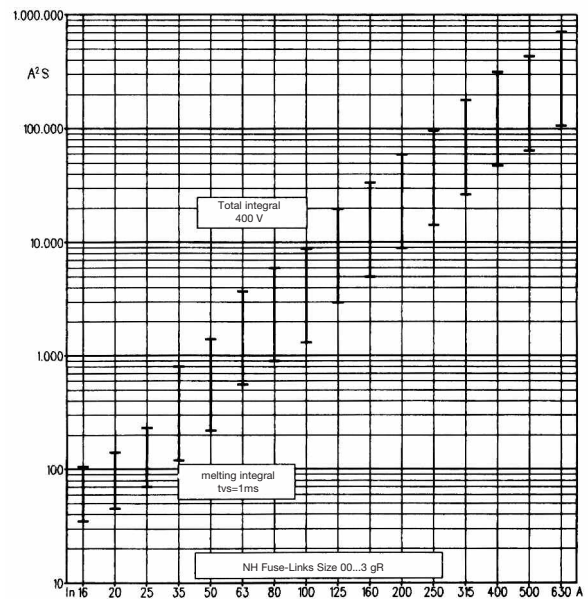

**Application:**

Instead using cable and line protection (gG) Fuse-Links, NH Maintenance Fuse-Links are temporary applied during maintenance in a power network. NH Maintenance Fuse-Links have an ultra rapid time-current characteristic. Thus the max. cut-off current and the cut-off energy is essentially stronger limited than in NH Fuse-Links of the operational classification gG. Thus meaning for the mechanic less hazard potential within appearance of a possible current arc. For normal operating, these NH Maintenance Fuse-Links are not quite suitable. They release too fast during a temporary overload. Furthermore the power dissipation is clearly higher than that of gG Fuse-Links. In this case we recommend our age resisting Fuse-Links utilization category gG.

- Less hazardous handling for the electrician because of minor cutoff current through a super rapid tripping characteristic
- Dead metal gripping lugs protect against electric shock
- Pure silver fuse element - resistant to aging
- Special prevention against slackening of screws
- - no problem whatsoever even after many years of application
- Clearly identified as NH Protection Fuse-Link

Size	Order no.	Amps	Description
2	35209-0010	80	NH-Arbeitssicherung 80A gR Li
2	35209-0020	100	NH-Arbeitssicherung 100A gR Li
2	35209-0030	125	NH-Arbeitssicherung 125A gR Li
2	35209-0040	160	NH-Arbeitssicherung 160A gR Li
2	35209-0050	200	NH-Arbeitssicherung 200A gR Li
2	35209-0060	224	NH-Arbeitssicherung 224A gR Li
2	35209-0070	250	NH-Arbeitssicherung 250A gR Li
2	35209-0080	300	NH-Arbeitssicherung 300A gR Li
2	35209-0090	315	NH-Arbeitssicherung 315A gR Li

**Comparison Maintenance Fuse-Link / gG**

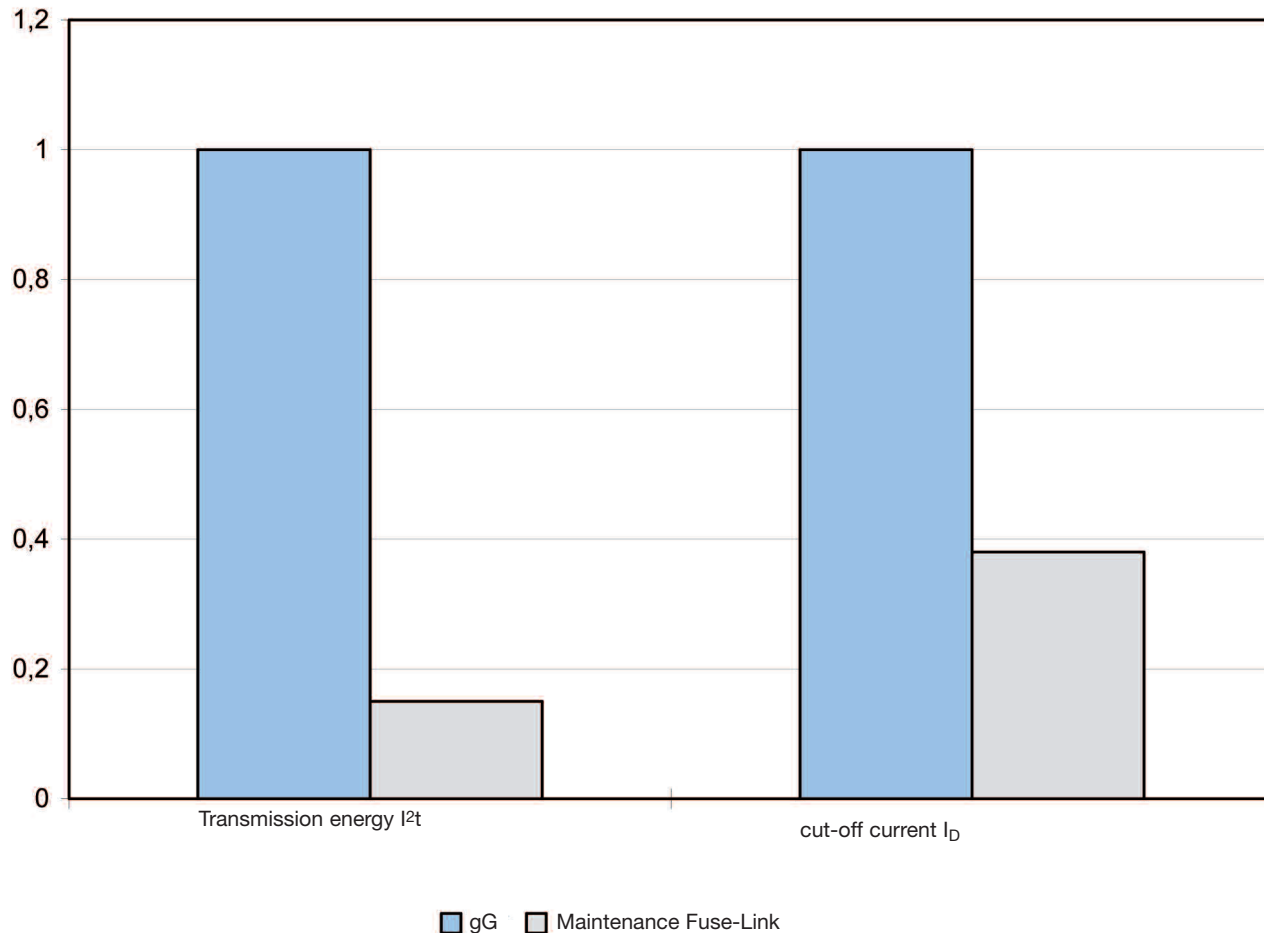



### For mining applications - Pure-silver fuse element

(Resistant to aging)

Rated voltage: AC 1000 V

Utilization category: gB and aM acc. VDE 0636/22

Application: gB - Protection of mining equipment

aM - Back up protection for mining equipment

Breaking capacity: 25 kA

### Electrical characteristics:

- NH Fuse-Links of utilization category gB
- NH Fuse-Links of utilization category aM are back-up fuses for the protection for motor circuits. They protect switchgear on occurrence of short circuits and together with the overcurrent protection devices a maximum safety is given to behind connected motors and switchgears. The use of pure silver fuse elements gives the Fuse-Links excellent aging resistance and reliable selectivity.

EFEN NH Fuse-Links aM are quick acting within the short circuit range, whereas no operation will be carried out on the overload range, as in this case the protection is effected by another over-current device.

Size	a <sub>1</sub>	a <sub>2</sub>	b	c	e <sub>1</sub>	e <sub>2</sub>	f	g
1L	170	105,5	24,5	40	45	45	10	105,5
3	167,5	92,5	32	60	72	72	15	80,5

Z

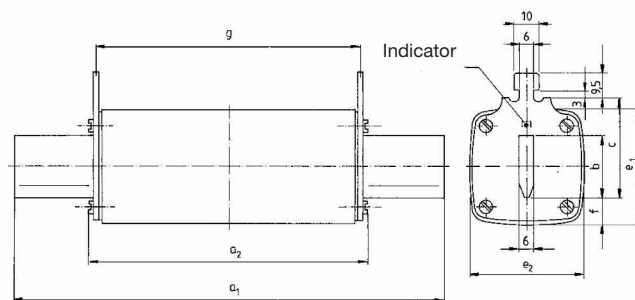

### Special designs and characteristics

Rated voltage: AC 1000 and 1500 V

Utilization category: TF acc. DIN 43 620/5

Application: Rectifier-substations for electric railways

Breaking capacity: 10 kA

### Electrical characteristics:

Special Fuse-Links for rectifier-substations for electric railways, having pure silver fuse-elements and dual time-current characteristic i.e., time-delay characteristic in the overcurrent range and quick-acting under short circuit conditions.

The use of pure silver fuse-elements gives the NH Fuse-Links excellent aging resistance.

Version with striker:

Parallel to the fuse-link a spring-loaded striker pin is mounted.

After the melting of the NH fuse-element the striker pin is released and operates a micro-switch on the NH fuse-base.

Size	a <sub>1</sub>	a <sub>2</sub>	b	c	e <sub>1</sub>	e <sub>2</sub>	f	g
3L	206	130	40	60	67	67	13,5	120

