

# SKiM301TMLI12E4B

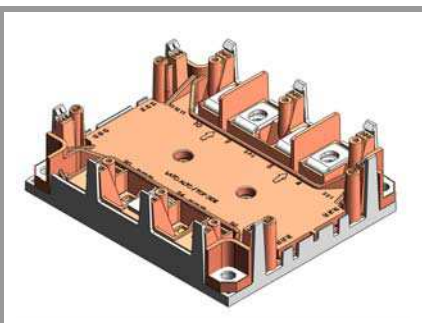

SKiM® 4

## Trench IGBT Modules

### SKiM301TMLI12E4B

#### Features

- IGBT 4 Trench Gate Technology
- Solder technology
- $V_{CE(sat)}$  with positive temperature coefficient
- Low inductance case
- Isolated by  $Al_2O_3$  DCB (Direct Copper Bonded) ceramic substrate
- Pressure contact technology for thermal contacts
- Spring contact system to attach driver PCB to the control terminals
- High short circuit capability, self limiting to  $6 \times I_C$
- Integrated temperature sensor

#### Typical Applications\*

- Automotive inverter
- High reliability AC inverter wind
- High reliability AC inverter drives

#### Remarks

- Case temperature limited to  $T_s = 125^\circ C$  max;  $T_c = T_s$  (for baseplateless modules)
- Recommended  $T_{op} = -40 \dots +150^\circ C$

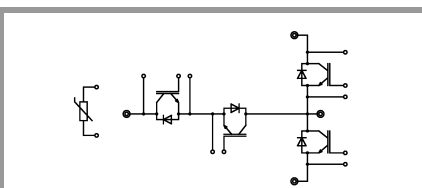

TMLI

Absolute Maximum Ratings			
Symbol	Conditions	Values	Unit
<b>IGBT 1</b>			
$V_{CES}$	$T_j = 25^\circ C$	1200	V
$I_C$	$T_j = 150^\circ C$	$T_s = 25^\circ C$	279
		$T_s = 70^\circ C$	213
$I_C$	$T_j = 175^\circ C$	$T_s = 25^\circ C$	311
		$T_s = 70^\circ C$	252
$I_{Cnom}$		300	A
$I_{CRM}$	$I_{CRM} = 3 \times I_{Cnom}$	900	A
$V_{GES}$		-20 ... 20	V
$t_{psc}$	$V_{CC} = 800 V$ $V_{GE} \leq 15 V$ $V_{CES} \leq 1200 V$	$T_j = 150^\circ C$	10
$T_j$		-40 ... 175	$^\circ C$

Absolute Maximum Ratings			
Symbol	Conditions	Values	Unit
<b>IGBT 2</b>			
$V_{CES}$	$T_j = 25^\circ C$	650	V
$I_C$	$T_j = 150^\circ C$	$T_s = 25^\circ C$	221
		$T_s = 70^\circ C$	164
$I_C$	$T_j = 175^\circ C$	$T_s = 25^\circ C$	248
		$T_s = 70^\circ C$	197
$I_{Cnom}$		300	A
$I_{CRM}$	$I_{CRM} = 2 \times I_{Cnom}$	600	A
$V_{GES}$		-20 ... 20	V
$t_{psc}$	$V_{CC} = 360 V$ $V_{GE} \leq 15 V$ $V_{CES} \leq 650 V$	$T_j = 150^\circ C$	10
$T_j$		-40 ... 175	$^\circ C$

Absolute Maximum Ratings			
Symbol	Conditions	Values	Unit
<b>Module</b>			
$I_{t(RMS)}$	$T_{terminal} = 80^\circ C,$	400	A
$T_{stg}$		-40 ... 125	$^\circ C$
$V_{isol}$	AC sinus 50 Hz, $t = 1 \text{ min}$	2500	V

# SKiM301TMLI12E4B

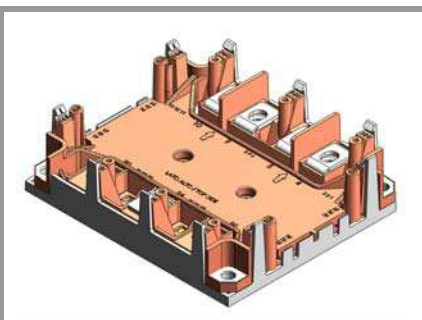

SKiM® 4

## Trench IGBT Modules

### SKiM301TMLI12E4B

#### Features

- IGBT 4 Trench Gate Technology
- Solder technology
- $V_{CE(sat)}$  with positive temperature coefficient
- Low inductance case
- Isolated by  $Al_2O_3$  DCB (Direct Copper Bonded) ceramic substrate
- Pressure contact technology for thermal contacts
- Spring contact system to attach driver PCB to the control terminals
- High short circuit capability, self limiting to  $6 \times I_C$
- Integrated temperature sensor

#### Typical Applications\*

- Automotive inverter
- High reliability AC inverter wind
- High reliability AC inverter drives

#### Remarks

- Case temperature limited to  $T_s = 125^\circ C$  max;  $T_C = T_s$  (for baseplateless modules)
- Recommended  $T_{op} = -40 \dots +150^\circ C$

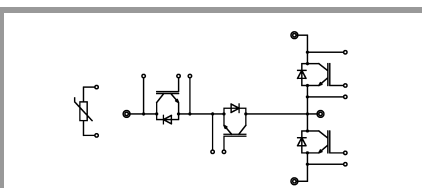

TMLI

Absolute Maximum Ratings				
Symbol	Conditions		Values	Unit
<b>Diode 1</b>				
$V_{RRM}$	$T_j = 25^\circ C$		1200	V
$I_F$	$T_j = 175^\circ C$	$T_s = 25^\circ C$	249	A
		$T_s = 70^\circ C$	196	A
$I_F$	$T_j = 175^\circ C$	$T_s = 25^\circ C$	249	A
		$T_s = 70^\circ C$	196	A
$I_{Fnom}$			300	A
$I_{FRM}$	$I_{FRM} = 3 \times I_{Fnom}$		900	A
$I_{FSM}$	10 ms, sin $180^\circ$ , $T_j = 150^\circ C$		1485	A
$T_j$			-40 ... 175	$^\circ C$

Absolute Maximum Ratings				
Symbol	Conditions		Values	Unit
<b>Diode 2</b>				
$V_{RRM}$	$T_j = 25^\circ C$		650	V
$I_F$	$T_j = 175^\circ C$	$T_s = 25^\circ C$	266	A
		$T_s = 70^\circ C$	205	A
$I_F$	$T_j = 175^\circ C$	$T_s = 25^\circ C$	266	A
		$T_s = 70^\circ C$	205	A
$I_{Fnom}$			300	A
$I_{FRM}$	$I_{FRM} = 2 \times I_{Fnom}$		600	A
$I_{FSM}$	10 ms sin $180^\circ$	$T_j = 25^\circ C$	2160	A
		$T_j = 150^\circ C$	1980	A
$T_j$			-40 ... 175	$^\circ C$

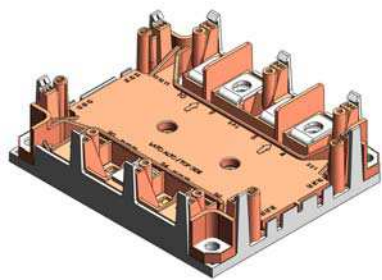

SKiM<sup>®</sup> 4

## Trench IGBT Modules

### SKiM301TMLI12E4B

#### Features

- IGBT 4 Trench Gate Technology
- Solder technology
- $V_{CE(sat)}$  with positive temperature coefficient
- Low inductance case
- Isolated by Al<sub>2</sub>O<sub>3</sub> DCB (Direct Copper Bonded) ceramic substrate
- Pressure contact technology for thermal contacts
- Spring contact system to attach driver PCB to the control terminals
- High short circuit capability, self limiting to 6 x I<sub>C</sub>
- Integrated temperature sensor

#### Typical Applications\*

- Automotive inverter
- High reliability AC inverter wind
- High reliability AC inverter drives

#### Remarks

- Case temperature limited to T<sub>s</sub> = 125°C max; T<sub>C</sub> = T<sub>s</sub> (for baseplateless modules)
- Recommended T<sub>op</sub> = -40 ... +150°C

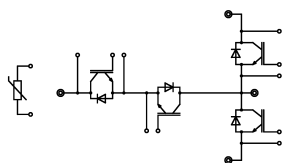

TMI

Characteristics						
Symbol	Conditions		min.	typ.	max.	Unit
<b>IGBT 1</b>						
V <sub>CE(sat)</sub>	I <sub>C</sub> = 300 A V <sub>GE</sub> = 15 V chiplevel	T <sub>j</sub> = 25 °C		1.80	2.05	V
		T <sub>j</sub> = 150 °C		2.20	2.40	V
V <sub>CE0</sub>	chiplevel	T <sub>j</sub> = 25 °C		0.8	0.9	V
		T <sub>j</sub> = 150 °C		0.7	0.8	V
r <sub>CE</sub>	V <sub>GE</sub> = 15 V chiplevel	T <sub>j</sub> = 25 °C		3.3	3.8	mΩ
		T <sub>j</sub> = 150 °C		5.0	5.3	mΩ
V <sub>GE(th)</sub>	V <sub>GE</sub> = V <sub>CE</sub> V, I <sub>C</sub> = 11.4 mA		5	5.8	6.5	V
I <sub>CES</sub>	V <sub>GE</sub> = 0 V	T <sub>j</sub> = 25 °C				mA
	V <sub>CE</sub> = 1200 V					mA
C <sub>ies</sub>	V <sub>CE</sub> = 25 V V <sub>GE</sub> = 0 V	f = 1 MHz		18.45		nF
C <sub>oes</sub>		f = 1 MHz		1.215		nF
C <sub>res</sub>		f = 1 MHz		1.035		nF
Q <sub>G</sub>	- 8 V...+ 15 V			1695		nC
R <sub>Gint</sub>	T <sub>j</sub> = 25 °C			2.50		Ω
t <sub>d(on)</sub>	V <sub>CE</sub> = 300 V	T <sub>j</sub> = 150 °C		217.9		ns
t <sub>r</sub>	I <sub>C</sub> = 300 A	T <sub>j</sub> = 150 °C		69.43		ns
E <sub>on</sub>	R <sub>G on</sub> = 2.7 Ω	T <sub>j</sub> = 150 °C		6.62		mJ
t <sub>d(off)</sub>	R <sub>G off</sub> = 2.7 Ω	T <sub>j</sub> = 150 °C		355.5		ns
t <sub>f</sub>	di/dt <sub>on</sub> = 5626 A/μs	T <sub>j</sub> = 150 °C		91.3		ns
E <sub>off</sub>	di/dt <sub>off</sub> = 2636 A/μs	T <sub>j</sub> = 150 °C		19.37		mJ
R <sub>th(j-s)</sub>	V <sub>GE neg</sub> = -15 V V <sub>GE pos</sub> = 15 V			0.19		K/W
	per IGBT					

Characteristics						
Symbol	Conditions		min.	typ.	max.	Unit
<b>IGBT 2</b>						
V <sub>CE(sat)</sub>	I <sub>C</sub> = 300 A V <sub>GE</sub> = 15 V chiplevel	T <sub>j</sub> = 25 °C		1.55	1.95	V
		T <sub>j</sub> = 150 °C		1.75	2.2	V
V <sub>CE0</sub>	chiplevel	T <sub>j</sub> = 25 °C		0.9	1	V
		T <sub>j</sub> = 150 °C		0.82	0.9	V
r <sub>CE</sub>	V <sub>GE</sub> = 15 V chiplevel	T <sub>j</sub> = 25 °C		2.2	3.2	mΩ
		T <sub>j</sub> = 150 °C		3.1	4.3	mΩ
V <sub>GE(th)</sub>	V <sub>GE</sub> = V <sub>CE</sub> V, I <sub>C</sub> = 8 mA		5.1	5.8	6.4	V
I <sub>CES</sub>	V <sub>GE</sub> = 0 V	T <sub>j</sub> = 25 °C				mA
	V <sub>CE</sub> = 650 V	T <sub>j</sub> = 150 °C				mA
C <sub>ies</sub>	V <sub>CE</sub> = 25 V V <sub>GE</sub> = 0 V	f = 1 MHz		18.48		nF
C <sub>oes</sub>		f = 1 MHz			nF	
C <sub>res</sub>		f = 1 MHz		0.548		nF
Q <sub>G</sub>	- 8 V...+ 15 V					nC
R <sub>Gint</sub>	T <sub>j</sub> = 25 °C			1.00		Ω
t <sub>d(on)</sub>	V <sub>CE</sub> = 300 V	T <sub>j</sub> = 150 °C		149.14		ns
t <sub>r</sub>	I <sub>C</sub> = 300 A	T <sub>j</sub> = 150 °C		79.71		ns
E <sub>on</sub>	R <sub>G on</sub> = 2.7 Ω	T <sub>j</sub> = 150 °C		2.78		mJ
	R <sub>G off</sub> = 2.7 Ω					
t <sub>d(off)</sub>	di/dt <sub>on</sub> = 5566 A/μs	T <sub>j</sub> = 150 °C		420		ns
t <sub>f</sub>	di/dt <sub>off</sub> = 1353 A/μs	T <sub>j</sub> = 150 °C		180		ns
E <sub>off</sub>	V <sub>GE neg</sub> = -15 V V <sub>GE pos</sub> = 15 V	T <sub>j</sub> = 150 °C		17.48		mJ
R <sub>th(j-s)</sub>	per IGBT			0.3		K/W

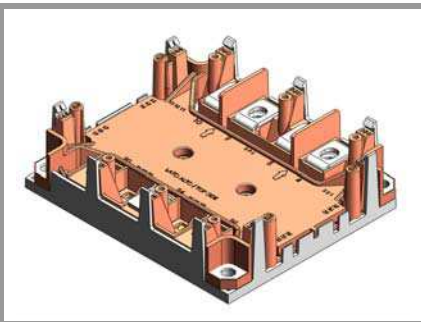

**SKiM® 4**

## Trench IGBT Modules

### SKiM301TMLI12E4B

#### Features

- IGBT 4 Trench Gate Technology
- Solder technology
- $V_{CE(sat)}$  with positive temperature coefficient
- Low inductance case
- Isolated by  $Al_2O_3$  DCB (Direct Copper Bonded) ceramic substrate
- Pressure contact technology for thermal contacts
- Spring contact system to attach driver PCB to the control terminals
- High short circuit capability, self limiting to  $6 \times I_C$
- Integrated temperature sensor

#### Typical Applications\*

- Automotive inverter
- High reliability AC inverter wind
- High reliability AC inverter drives

#### Remarks

- Case temperature limited to  $T_s = 125^\circ C$  max;  $T_C = T_s$  (for baseplateless modules)
- Recommended  $T_{op} = -40 \dots +150^\circ C$

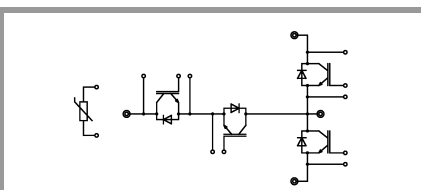

**TMLI**

Characteristics						
Symbol	Conditions		min.	typ.	max.	Unit
<b>Diode 1</b>						
$V_F = V_{EC}$	$I_F = 300\text{ A}$ $V_{GE} = 15\text{ V}$ chipelevel	$T_j = 25^\circ C$		2.20	2.52	V
		$T_j = 150^\circ C$		2.15	2.47	V
$V_{F0}$	chipelevel	$T_j = 25^\circ C$	1.1	1.3	1.5	V
		$T_j = 150^\circ C$	0.7	0.9	1.1	V
$r_F$	chipelevel	$T_j = 25^\circ C$	2.7	3.0	3.4	m $\Omega$
		$T_j = 150^\circ C$	3.5	4.2	4.6	m $\Omega$
$I_{RRM}$	$I_F = 300\text{ A}$			132.43		A
$Q_{rr}$				21.47		$\mu C$
$E_{rr}$	$V_R = 300\text{ V}$			1.79		mJ
$R_{th(j-s)}$	per DIODE			0.29		K/W

Characteristics						
Symbol	Conditions		min.	typ.	max.	Unit
<b>Diode 2</b>						
$V_F = V_{EC}$	$I_F = 300\text{ A}$ chipelevel	$T_j = 25^\circ C$		1.4	1.80	V
		$T_j = 150^\circ C$		1.39	1.77	V
$V_{F0}$	chipelevel	$T_j = 25^\circ C$	0.95	1.04	1.236	V
		$T_j = 150^\circ C$		0.85	0.99	V
$r_F$	chipelevel	$T_j = 25^\circ C$	0.8	1.2	1.8	m $\Omega$
		$T_j = 150^\circ C$		1.8	2.6	m $\Omega$
$I_{RRM}$	$I_F = 300\text{ A}$			126.64		A
$Q_{rr}$				23.84		$\mu C$
$E_{rr}$	$V_R = 300\text{ V}$			1.7		mJ
$R_{th(j-s)}$	per DIODE			0.35		K/W

# SKiM301TMLI12E4B

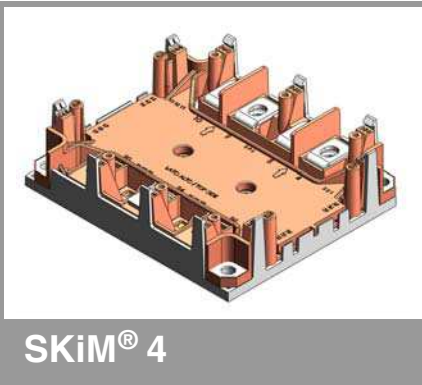

## Trench IGBT Modules

### SKiM301TMLI12E4B

#### Features

- IGBT 4 Trench Gate Technology
- Solder technology
- $V_{CE(sat)}$  with positive temperature coefficient
- Low inductance case
- Isolated by  $Al_2O_3$  DCB (Direct Copper Bonded) ceramic substrate
- Pressure contact technology for thermal contacts
- Spring contact system to attach driver PCB to the control terminals
- High short circuit capability, self limiting to  $6 \times I_C$
- Integrated temperature sensor

#### Typical Applications\*

- Automotive inverter
- High reliability AC inverter wind
- High reliability AC inverter drives

#### Remarks

- Case temperature limited to  $T_s = 125^\circ C$  max;  $T_C = T_s$  (for baseplateless modules)
- Recommended  $T_{op} = -40 \dots +150^\circ C$

Characteristics						
Symbol	Conditions		min.	typ.	max.	Unit
<b>Module</b>						
$L_{CE}$				18		nH
$R_{CC'+EE'}$	terminal-chip	$T_s = 25^\circ C$		1.35		$m\Omega$
		$T_s = 125^\circ C$		1.75		$m\Omega$
$R_{th(c-s)}$	per module					K/W
$M_s$	to heat sink (M5)		2		3	Nm
$M_t$		to terminals M6	4		5	Nm
						Nm
$w$				317		g

Characteristics						
Symbol	Conditions		min.	typ.	max.	Unit
<b>Temperature Sensor</b>						
$R_{100}$	$T_r = 100^\circ C$ , tolerance = 3 %			$493 \pm 5\%$		$\Omega$
$B_{100/125}$	$R_{(T)} = R_{100} \exp[B_{100/125}(1/T - 1/T_{100})]$ ; $T[K]$ ;			$3550 \pm 2\%$		K

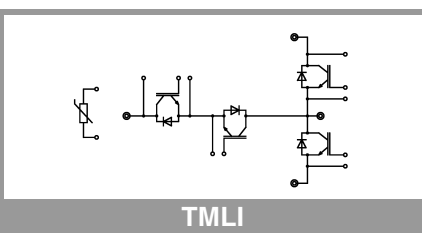

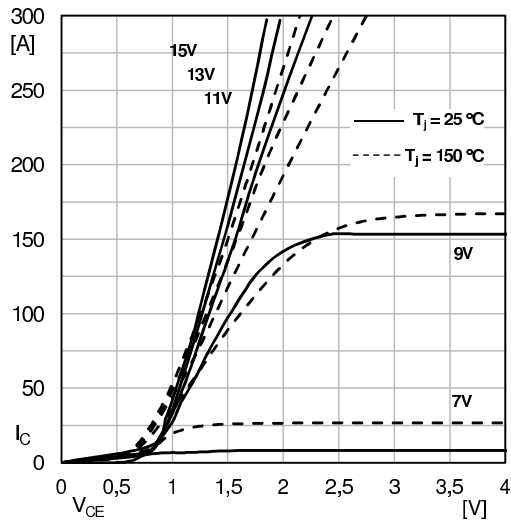

Fig. 1: Typ. output characteristic, inclusive  $R_{CC+EE}$

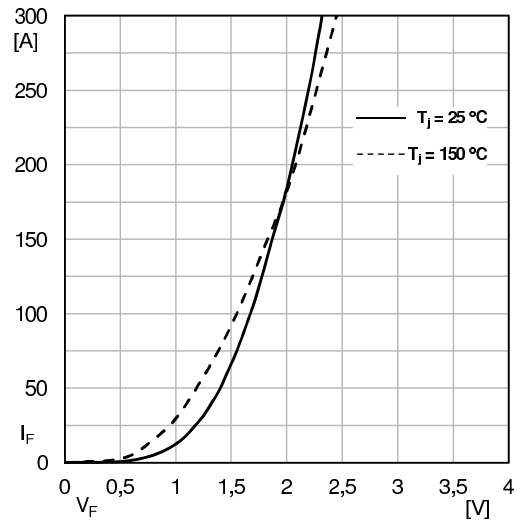

Fig. 2: Rated current vs. temperature  $I_C = f(T_C)$

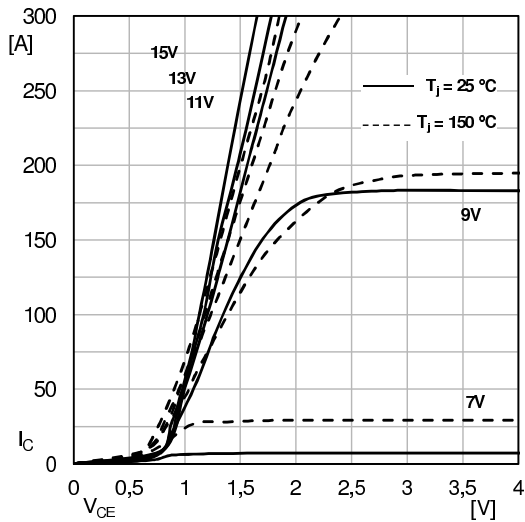

Fig. 3: Typ. turn-on /-off energy =  $f(I_C)$

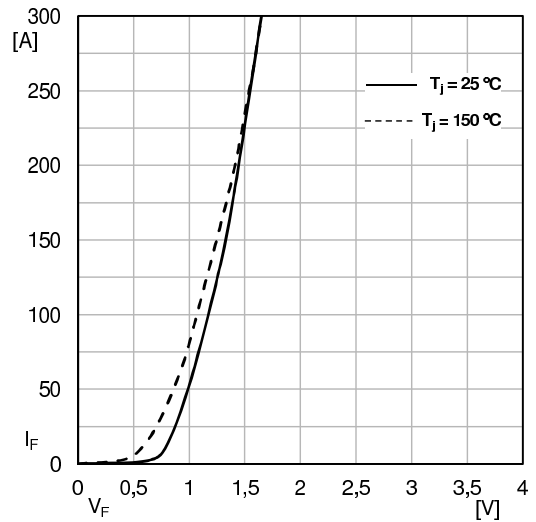

Fig. 4: Typ. turn-on /-off energy =  $f(R_G)$

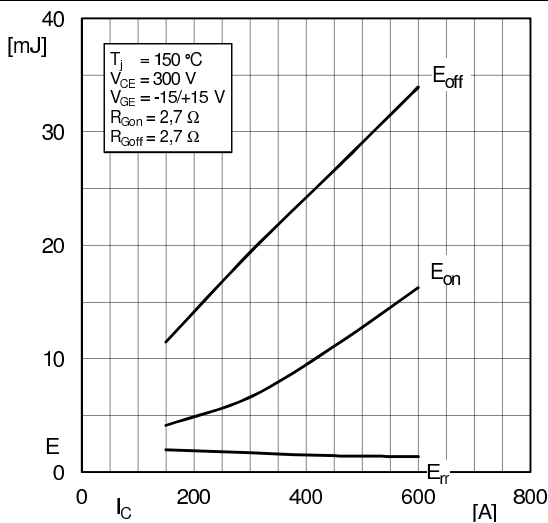

Fig. 5: Typ. transfer characteristic

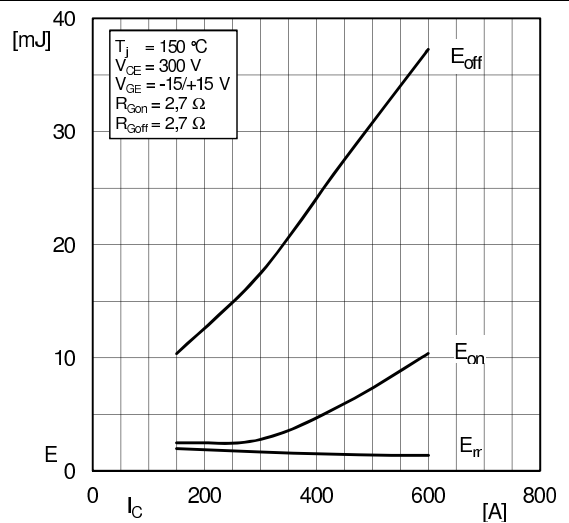

Fig. 6: Typ. gate charge characteristic

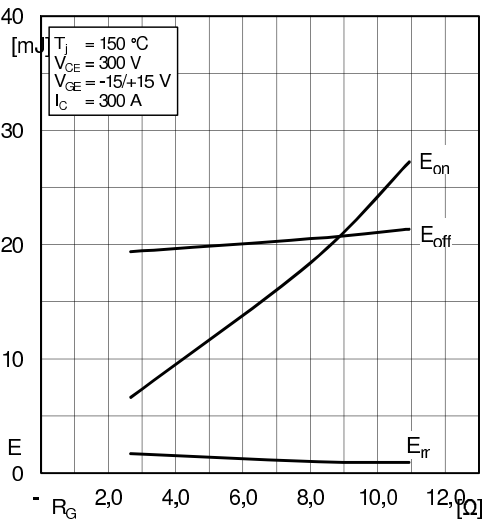

Fig. 7: Typ. switching times vs.  $I_C$

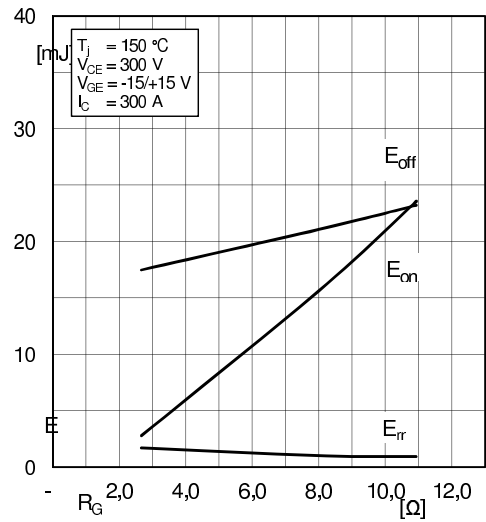

Fig. 8: Typ. switching times vs. gate resistor  $R_G$

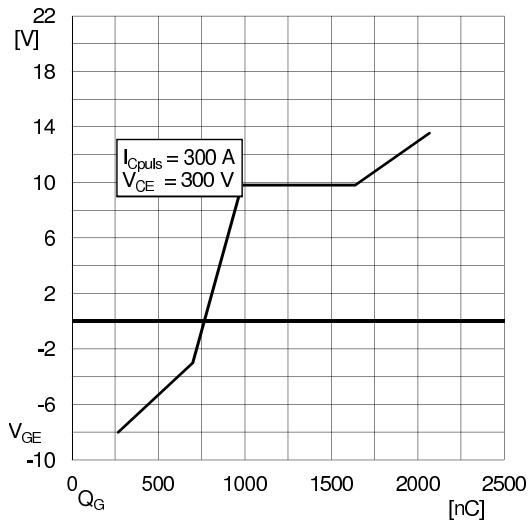

Fig. 9: Typ. transient thermal impedance

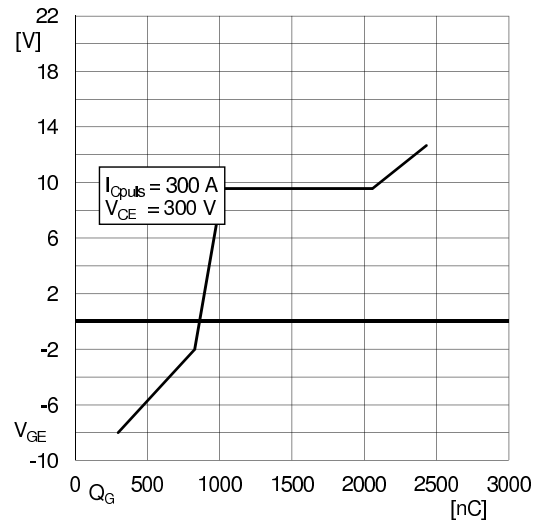

Fig. 10: Typ. CAL diode forward charact., incl.  $R_{CC'+EE'}$

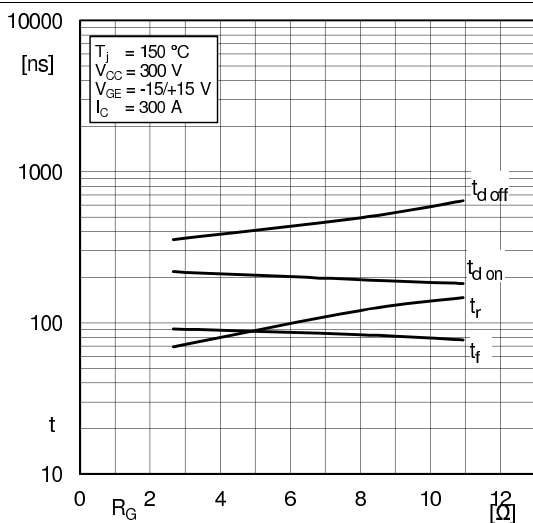

Fig. 11: Typ. diodes transient thermal impedance

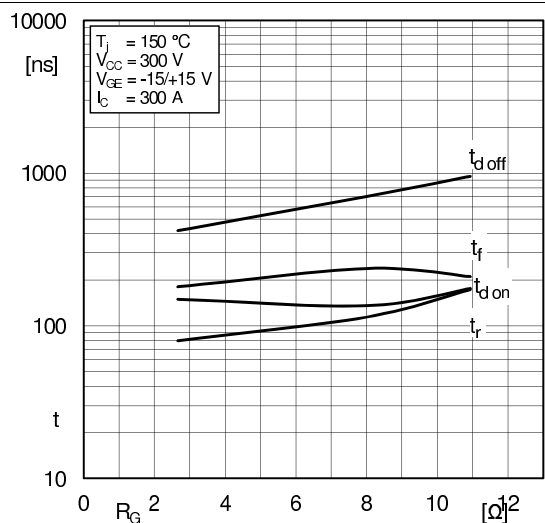
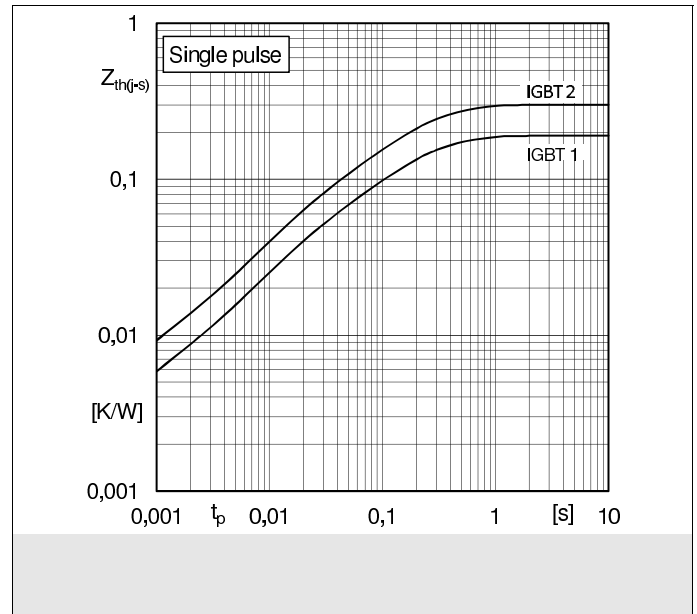
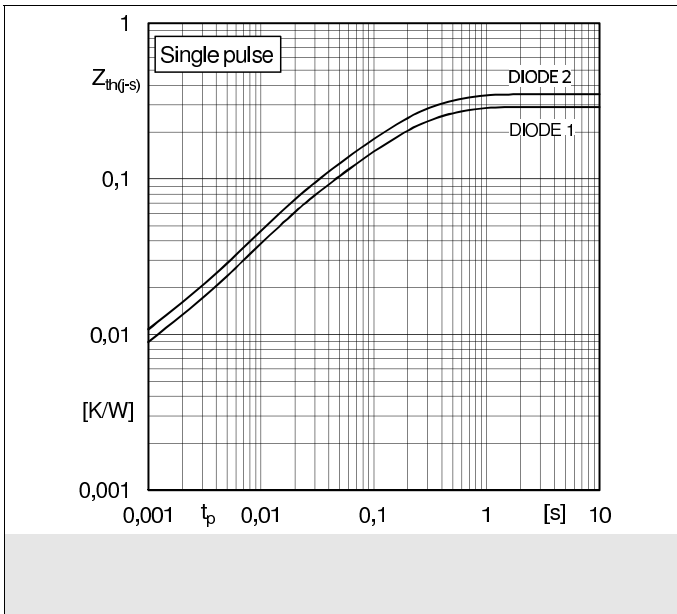
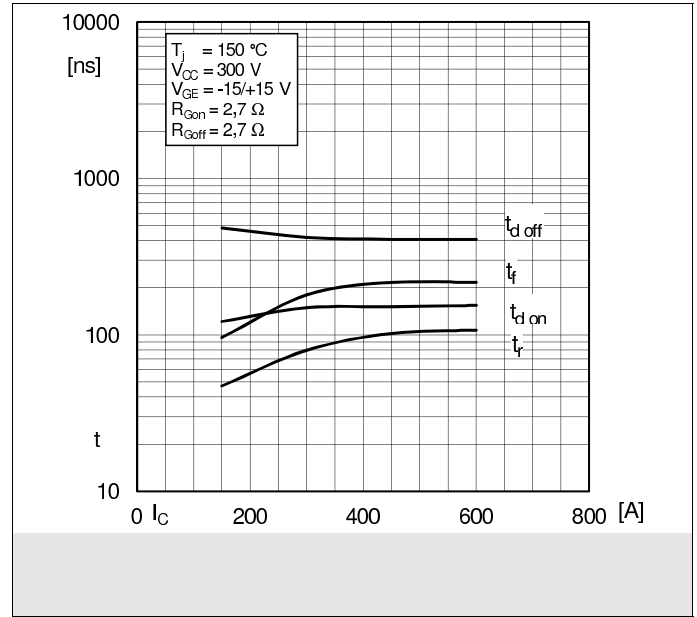
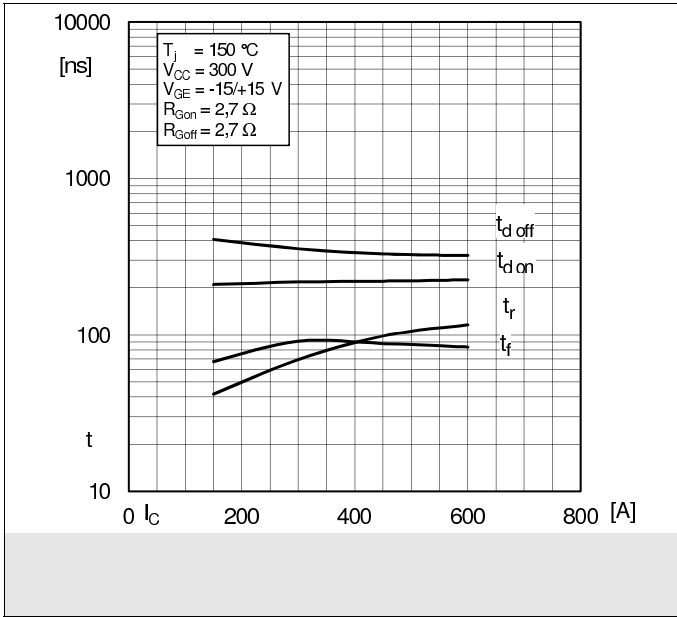
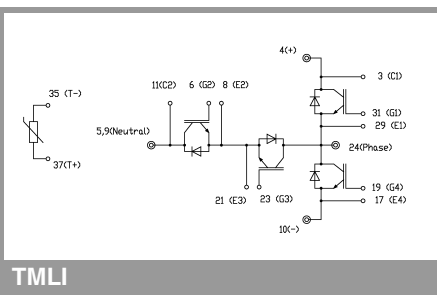
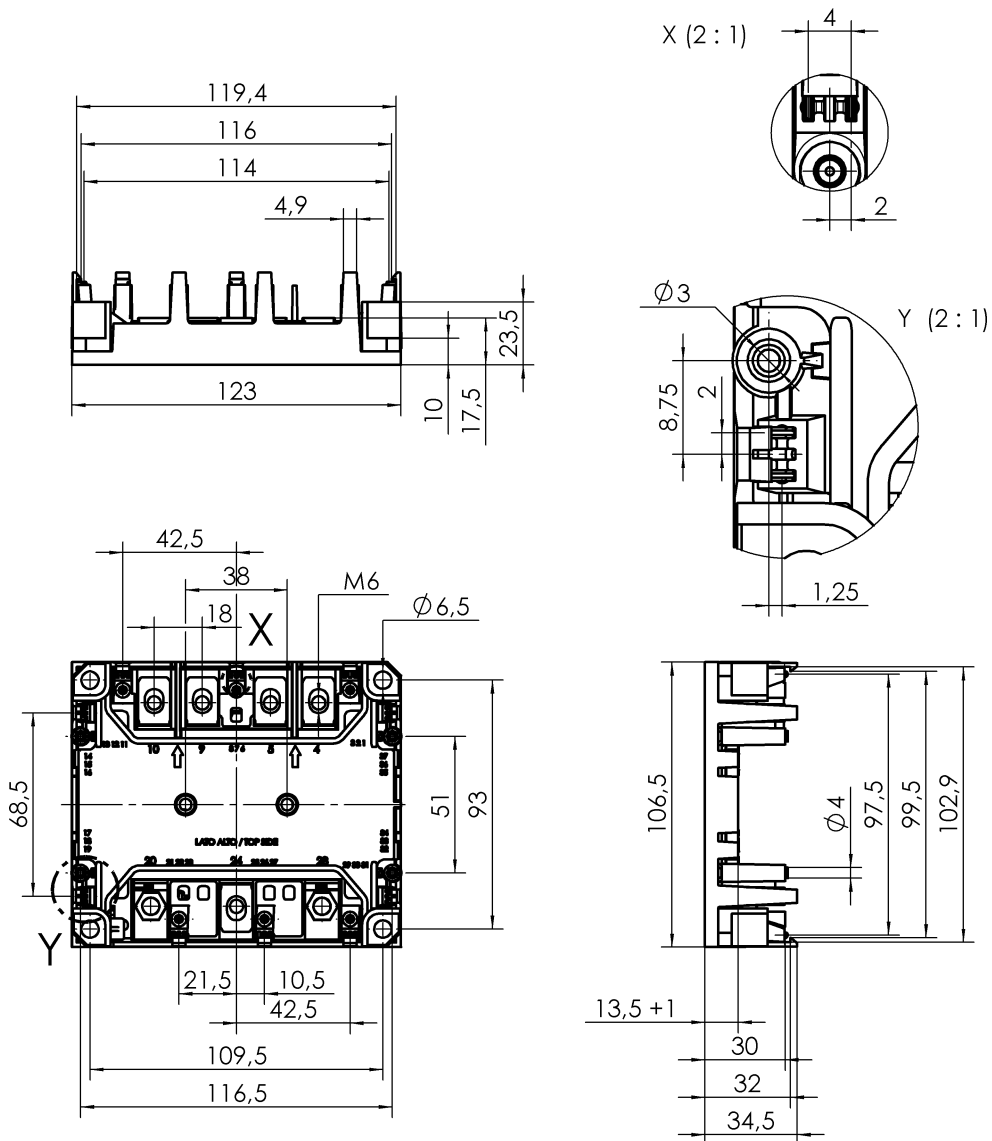

Fig. 12: Typ. IGBTs transient thermal impedance





# SKiM301TMLI12E4B



TM LI

This is an electrostatic discharge sensitive device (ESDS), international standard IEC 60747-1, Chapter IX

\* The specifications of our components may not be considered as an assurance of component characteristics. Components have to be tested for the respective application. Adjustments may be necessary. The use of SEMIKRON products in life support appliances and systems is subject to prior specification and written approval by SEMIKRON. We therefore strongly recommend prior consultation of our staff.