

**SIEMENS**



# SIMATIC

S7-1500

CPU 1513-1 PN (6ES7513-1AL01-0AB0)

Manual

Edition

09/2016

[siemens.com](http://siemens.com)

# SIEMENS

## SIMATIC

S7-1500  
CPU 1513-1 PN  
(6ES7513-1AL01-0AB0)

Manual

Preface

---

Documentation guide

---

1

Product overview

---

2

Connecting up

---

3

Interrupts, error messages,  
diagnostics and system  
alarms

---

4

Technical specifications

---

5

Dimensional drawing



---

A

## Legal information

### Warning notice system

This manual contains notices you have to observe in order to ensure your personal safety, as well as to prevent damage to property. The notices referring to your personal safety are highlighted in the manual by a safety alert symbol, notices referring only to property damage have no safety alert symbol. These notices shown below are graded according to the degree of danger.

 <b>DANGER</b>
indicates that death or severe personal injury <b>will</b> result if proper precautions are not taken.
 <b>WARNING</b>
indicates that death or severe personal injury <b>may</b> result if proper precautions are not taken.
 <b>CAUTION</b>
indicates that minor personal injury can result if proper precautions are not taken.
<b>NOTICE</b>
indicates that property damage can result if proper precautions are not taken.

If more than one degree of danger is present, the warning notice representing the highest degree of danger will be used. A notice warning of injury to persons with a safety alert symbol may also include a warning relating to property damage.

### Qualified Personnel

The product/system described in this documentation may be operated only by **personnel qualified** for the specific task in accordance with the relevant documentation, in particular its warning notices and safety instructions. Qualified personnel are those who, based on their training and experience, are capable of identifying risks and avoiding potential hazards when working with these products/systems.

### Proper use of Siemens products

Note the following:

 <b>WARNING</b>
Siemens products may only be used for the applications described in the catalog and in the relevant technical documentation. If products and components from other manufacturers are used, these must be recommended or approved by Siemens. Proper transport, storage, installation, assembly, commissioning, operation and maintenance are required to ensure that the products operate safely and without any problems. The permissible ambient conditions must be complied with. The information in the relevant documentation must be observed.

### Trademarks

All names identified by ® are registered trademarks of Siemens AG. The remaining trademarks in this publication may be trademarks whose use by third parties for their own purposes could violate the rights of the owner.

### Disclaimer of Liability

We have reviewed the contents of this publication to ensure consistency with the hardware and software described. Since variance cannot be precluded entirely, we cannot guarantee full consistency. However, the information in this publication is reviewed regularly and any necessary corrections are included in subsequent editions.

# Preface

## Purpose of the documentation

This manual supplements the system manual of the S7-1500 automation system/ ET 200MP distributed I/O system as well as the function manuals. This manual contains a description of the module-specific information. The system-related functions are described in the system manual. All system-spanning functions are described in the function manuals.

The information provided in this manual and the system manual enables you to commission the CPU 1513-1 PN.

## Conventions

STEP 7: In this documentation, "STEP 7" is used as a synonym for all versions of the configuration and programming software "STEP 7 (TIA Portal)".

Please also observe notes marked as follows:

---

### Note

A note contains important information on the product described in the documentation, on the handling of the product or on the section of the documentation to which particular attention should be paid.

---

## Security information

Siemens provides products and solutions with industrial security functions that support the secure operation of plants, systems, machines and networks.

In order to protect plants, systems, machines and networks against cyber threats, it is necessary to implement – and continuously maintain – a holistic, state-of-the-art industrial security concept. Siemens' products and solutions only form one element of such a concept.

Customer is responsible to prevent unauthorized access to its plants, systems, machines and networks. Systems, machines and components should only be connected to the enterprise network or the internet if and to the extent necessary and with appropriate security measures (e.g. use of firewalls and network segmentation) in place.

Additionally, Siemens' guidance on appropriate security measures should be taken into account. For more information about industrial security, please visit (<http://www.siemens.com/industrialsecurity>).

Siemens' products and solutions undergo continuous development to make them more secure. Siemens strongly recommends to apply product updates as soon as available and to always use the latest product versions. Use of product versions that are no longer supported, and failure to apply latest updates may increase customer's exposure to cyber threats.

To stay informed about product updates, subscribe to the Siemens Industrial Security RSS Feed under (<http://www.siemens.com/industrialsecurity>).

## Siemens Industry Online Support

You can find current information on the following topics quickly and easily here:

- **Product support**

All the information and extensive know-how on your product, technical specifications, FAQs, certificates, downloads, and manuals.

- **Application examples**

Tools and examples to solve your automation tasks – as well as function blocks, performance information and videos.

- **Services**

Information about Industry Services, Field Services, Technical Support, spare parts and training offers.

- **Forums**

For answers and solutions concerning automation technology.

- **mySupport**

Your personal working area in Industry Online Support for messages, support queries, and configurable documents.

This information is provided by the Siemens Industry Online Support in the Internet (<http://www.siemens.com/automation/service&support>).

## Industry Mall

The Industry Mall is the catalog and order system of Siemens AG for automation and drive solutions on the basis of Totally Integrated Automation (TIA) and Totally Integrated Power (TIP).

Catalogs for all the products in automation and drives are available on the Internet (<https://mall.industry.siemens.com>).

# Table of contents

	<b>Preface</b> .....	<b>4</b>
<b>1</b>	<b>Documentation guide</b> .....	<b>7</b>
<b>2</b>	<b>Product overview</b> .....	<b>11</b>
2.1	New functions in firmware version V2.0.....	11
2.2	Applications of the S7-1500 CPU .....	13
2.3	How it works .....	18
2.4	Properties .....	19
2.5	Operating and display elements .....	23
2.5.1	Front view of the module with closed front panel.....	23
2.5.2	Front view of the module without front panel .....	25
2.5.3	Rear view of the module .....	26
2.6	Mode selector switch .....	26
<b>3</b>	<b>Connecting up</b> .....	<b>27</b>
<b>4</b>	<b>Interrupts, error messages, diagnostics and system alarms</b> .....	<b>30</b>
4.1	Status and error display of the CPU .....	30
<b>5</b>	<b>Technical specifications</b> .....	<b>33</b>
<b>A</b>	<b>Dimensional drawing</b> .....	<b>44</b>

## Documentation guide

The documentation for the SIMATIC S7-1500 automation system, the CPU 1516pro-2 PN based on SIMATIC S7-1500 and the SIMATIC ET 200MP distributed I/O system is arranged into three areas.

This arrangement enables you to access the specific content you require.

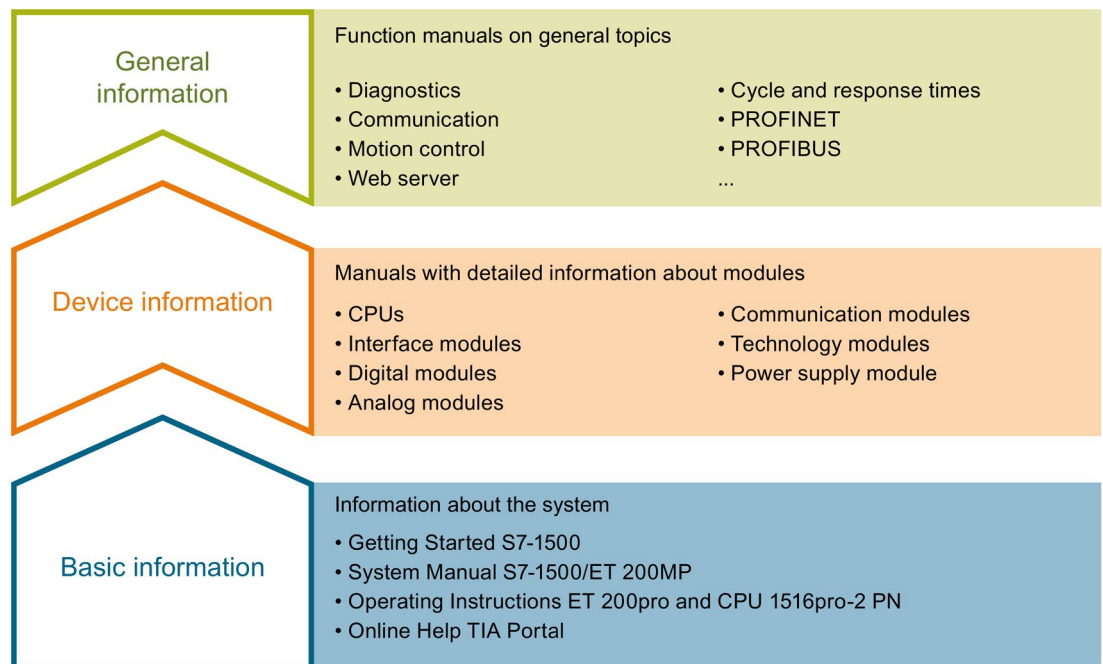

### Basic information

The System Manual and Getting Started describe in detail the configuration, installation, wiring and commissioning of the SIMATIC S7-1500 and ET 200MP systems. For CPU 1516pro-2 PN you use the corresponding operating instructions. The STEP 7 online help supports you in the configuration and programming.

### Device information

Product manuals contain a compact description of the module-specific information, such as properties, wiring diagrams, characteristics and technical specifications.

### General information

The function manuals contain detailed descriptions on general topics regarding the SIMATIC S7-1500 and ET 200MP systems, e.g. diagnostics, communication, motion control, Web server, OPC UA.

You can download the documentation free of charge from the Internet (<http://w3.siemens.com/mcms/industrial-automation-systems-simatic/en/manual-overview/Pages/Default.aspx>).

Changes and supplements to the manuals are documented in a Product Information.

You can download the product information free of charge from the Internet (<https://support.industry.siemens.com/cs/us/en/view/68052815>).

### Manual Collection S7-1500/ET 200MP

The Manual Collection contains the complete documentation on the SIMATIC S7-1500 automation system and the ET 200MP distributed I/O system gathered together in one file.

You can find the Manual Collection on the Internet (<https://support.industry.siemens.com/cs/ww/en/view/86140384>).

### SIMATIC S7-1500 comparison list for programming languages

The comparison list contains an overview of which instructions and functions you can use for which controller families.

You can find the comparison list on the Internet (<https://support.industry.siemens.com/cs/ww/en/view/86630375>).

### "mySupport"

With "mySupport", your personal workspace, you make the best out of your Industry Online Support.

In "mySupport", you can save filters, favorites and tags, request CAx data and compile your personal library in the Documentation area. In addition, your data is already filled out in support requests and you can get an overview of your current requests at any time.

You must register once to use the full functionality of "mySupport".

You can find "mySupport" on the Internet (<https://support.industry.siemens.com/My/ww/en>).

### "mySupport" - Documentation

In the Documentation area in "mySupport" you can combine entire manuals or only parts of these to your own manual.

You can export the manual as PDF file or in a format that can be edited later.

You can find "mySupport" - Documentation on the Internet (<http://support.industry.siemens.com/My/ww/en/documentation>).

## "mySupport" - CAx data

In the CAx data area in "mySupport", you can access the current product data for your CAx or CAe system.

You configure your own download package with a few clicks.

In doing so you can select:

- Product images, 2D dimension drawings, 3D models, internal circuit diagrams, EPLAN macro files
- Manuals, characteristics, operating manuals, certificates
- Product master data

You can find "mySupport" - CAx data on the Internet (<http://support.industry.siemens.com/my/ww/en/CAxOnline>).

## Application examples

The application examples support you with various tools and examples for solving your automation tasks. Solutions are shown in interplay with multiple components in the system - separated from the focus on individual products.

You will find the application examples on the Internet (<https://support.industry.siemens.com/sc/ww/en/sc/2054>).

## TIA Selection Tool

With the TIA Selection Tool, you can select, configure and order devices for Totally Integrated Automation (TIA).

This tool is the successor of the SIMATIC Selection Tool and combines the known configurators for automation technology into one tool.

With the TIA Selection Tool, you can generate a complete order list from your product selection or product configuration.

You can find the TIA Selection Tool on the Internet (<http://w3.siemens.com/mcms/topics/en/simatic/tia-selection-tool>).

## SIMATIC Automation Tool

You can use the SIMATIC Automation Tool to run commissioning and maintenance activities simultaneously on various SIMATIC S7 stations as a bulk operation independently of the TIA Portal.

The SIMATIC Automation Tool provides a multitude of functions:

- Scanning of a PROFINET/Ethernet network and identification of all connected CPUs
- Address assignment (IP, subnet, gateway) and station name (PROFINET device) to a CPU
- Transfer of the date and the programming device/PC time converted to UTC time to the module
- Program download to CPU
- Operating mode switchover RUN/STOP
- Localization of the CPU by means of LED flashing
- Reading out CPU error information
- Reading the CPU diagnostic buffer
- Reset to factory settings
- Updating the firmware of the CPU and connected modules

You can find the SIMATIC Automation Tool on the Internet (<https://support.industry.siemens.com/cs/ww/en/view/98161300>).

## PRONETA

With SIEMENS PRONETA (PROFINET network analysis), you analyze the PROFINET network during commissioning. PRONETA features two core functions:

- The topology overview independently scans PROFINET and all connected components.
- The IO check is a fast test of the wiring and the module configuration of a system.

You can find SIEMENS PRONETA on the Internet (<https://support.industry.siemens.com/cs/ww/en/view/67460624>).

## Product overview

### 2.1 New functions in firmware version V2.0

#### New functions of the CPU in firmware version V2.0

This section lists the new features of the CPU with firmware version V2.0.

You can find additional information in the sections of this manual.

Table 2- 1 New functions of the CPU with firmware version 2.0 compared with firmware version V1.8

New functions	Applications	Customer benefits
<b>OPC UA server</b>	<p>You realize the data communication between different systems, both within the process level and on the control and enterprise levels:</p> <ul style="list-style-type: none"> <li>To embedded systems with controllers</li> <li>To controllers with MES systems and systems of the enterprise level (ERP, asset systems)</li> <li>To Siemens controllers with controllers from other manufacturers</li> <li>To intelligent sensors with controllers</li> </ul> <p>Supported standard: OPC Data Access, DA.</p>	<p>OPC UA is a unified standard for data communication and is independent of any particular operating system platforms.</p> <p>You have integrated security mechanisms on different automation systems, for example, for data exchange, on the application level, for authentication of the user.</p> <p>OPC UA servers provide a large amount of data:</p> <ul style="list-style-type: none"> <li>Values of PLC tags that clients can access</li> <li>Data types of these PLC tags</li> <li>Information about the OPC UA server itself and the CPU</li> </ul> <p>In this way, clients can gain an overview and can read and write values.</p>
<b>PROFINET IO</b>		
MRPD: Media Redundancy for Planned Duplication for IRT	PROFINET IO IRT enables you to realize applications that place particularly high demands on failure safety and accuracy (isochronous).	By sending the cyclic IO data in both directions in the ring, the communication to the IO devices is maintained even when the ring is interrupted and does not result in device failure even with fast update times. You achieve higher failure safety than with MRP.
PROFINET performance upgrade	You can develop applications with high demands on speed and clock cycles. This is interesting for applications with high demands on performance.	Better utilization of the bandwidth results in short reaction times.
Limitation of the data infeed into the network	You limit the network load for standard Ethernet communication to a maximum value.	You smooth peaks in the data infeed. You share the remaining bandwidth based on requirements.
<b>Display and Web server</b>		
Backing up and restoring via the display	You can back up and restore the CPU configuration to/from the SIMATIC memory card without a programming device/PC.	You can make a backup copy of an operational project without STEP 7.

2.1 New functions in firmware version V2.0

New functions	Applications	Customer benefits
Backing up and restoring via the Web server	You can, for example, backup and restore the configuration of the CPU to the PG/PC on which the Web server is running.	In an "emergency", you can simply use an existing configuration without STEP 7, for example, during commissioning or after a program download.
Display and Web server provide up to three project languages for comments and message texts	When you export your plants worldwide, for example, comments or message texts can be stored on the card in up to 3 languages. For example, German - author's language, English - internationally usable, Portuguese - end user's language.	You provide customers with better service.
Trace via Web server	When you enable trace functions via the Web server, you have better service support. You can send your trace recordings via Web service, for example, to your service partner.	You get plant/project information for diagnostics and maintenance requirements without STEP 7. You can provide trace recordings for each Web server.
Monitoring of configured technology objects via a Web server	You can monitor statuses, errors, technology alarms and the current values of technology objects (TOs) with the Web server.	You save time in troubleshooting.
Formatting, erasing or converting a SIMATIC memory card via the display	Your SIMATIC memory card is directly formatted, erased or converted to a program card without having to use STEP 7. You save time.	
<b>Motion control</b>		
Greater number of axes for Motion Control applications and new technology objects: Output cam, cam track and measuring input	<p>Speed specification, e.g. for:</p> <ul style="list-style-type: none"> <li>• Pumps, fans, mixers</li> <li>• Conveyor belts</li> <li>• Auxiliary drives</li> </ul> <p>Positioning tasks, e.g.:</p> <ul style="list-style-type: none"> <li>• Lifting and vertical conveyors</li> <li>• Feeding and gate control</li> <li>• Palletizing equipment</li> </ul> <p>Output cams and cam tracks make other applications possible, e.g.:</p> <ul style="list-style-type: none"> <li>• Applying glue tracks</li> <li>• Triggering switching operations with precise positioning</li> <li>• Very precise processing of products on a conveyor belt</li> </ul> <p>Measuring inputs are used, for example:</p> <ul style="list-style-type: none"> <li>• For measuring products</li> <li>• For detecting the position of the product on a conveyor belt</li> </ul>	<p>You can implement additional Motion Control applications with a CPU.</p> <p>The scalable configuration limits allow you to handle all types of application.</p> <p>High machine speeds result in greater productivity with better accuracy.</p>

## 2.2 Applications of the S7-1500 CPU

### Area of application

SIMATIC S7-1500 is the modular control system for a wide variety of automation applications in discrete automation.

The modular and fanless design, simple implementation of distributed structures, and user-friendly operation make SIMATIC S7-1500 the economic and convenient solution for a variety of tasks.

Applications of the SIMATIC S7-1500, include, for example:

- Special-purpose machines
- Textile machinery
- Packaging machines
- General mechanical engineering
- Controller engineering
- Machine tool engineering
- Installation engineering
- Electrical industry and crafts
- Automobile engineering
- Water/waste water
- Food & Beverage

Applications of the SIMATIC S7-1500T include, for example:

- Packaging machines
- Converting application
- Assembly automation

Several CPUs with various levels of performance and a comprehensive range of modules with many convenient features are available. Fail-safe CPUs enable use in fail-safe applications. The modular design allows you to use only the modules that you need for your application. The controller can be retrofitted with additional modules at any time to expand its range of tasks.

High industrial capability from the high resistance to EMC, shock and vibration enable universal use of the SIMATIC S7-1500.

**Performance segments of the standard, compact, fail-safe and technology CPUs**

The CPUs can be used for smaller and mid-range applications, as well as for the high-end range of machine and plant automation.

Table 2- 2 Standard CPUs

CPU	Performance segment	PROFIBUS interfaces	PROFINET IO RT/IRT interfaces	PROFINET IO RT interface	PROFINET basic functionality	Work memory	Processing time for bit operations
CPU 1511-1 PN	Standard CPU for small to mid-range applications	--	1	--	--	1.23 MB	60 ns
CPU 1513-1 PN	Standard CPU for mid-range applications	--	1	--	--	1.95 MB	40 ns
CPU 1515-2 PN	Standard CPU for mid-range to large applications	--	1	1	--	3.75 MB	30 ns
CPU 1516-3 PN/DP	Standard CPU for demanding applications and communication tasks	1	1	1	--	6.5 MB	10 ns
CPU 1517-3 PN/DP	Standard CPU for demanding applications and communication tasks	1	1	1	--	11 MB	2 ns
CPU 1518-4 PN/DP CPU 1518-4 PN/DP ODK	Standard CPU for high-performance applications, demanding communication tasks and very short reaction times	1	1	1	1	26 MB	1 ns

Table 2- 3 Compact CPUs

CPU	Performance segment	PROFIBUS interfaces	PROFINET IO RT/IRT interfaces	PROFINET IO RT interface	PROFINET basic functionality	Work memory	Processing time for bit operations
CPU 1511C-1 PN	Compact CPU for small to mid-range applications	--	1	--	--	1.175 MB	60 ns
CPU 1512C-1 PN	Compact CPU for mid-range applications	--	1	--	--	1.25 MB	48 ns

Table 2- 4 Fail-safe CPUs

CPU	Performance segment	PROFIBUS interfaces	PROFINET IO RT/IRT interfaces	PROFINET IO RT interface	PROFINET basic functionality	Work memory	Processing time for bit operations
CPU 1511F-1 PN	Fail-safe CPU for small to mid-range applications	--	1	--	--	1.23 MB	60 ns
CPU 1513F-1 PN	Fail-safe CPU for mid-range applications	--	1	--	--	1.95 MB	40 ns
CPU 1515F-2 PN	Fail-safe CPU for mid-range to large applications	--	1	1	--	3.75 MB	30 ns
CPU 1516F-3 PN/DP	Fail-safe CPU for demanding applications and communication tasks	1	1	1	--	6.5 MB	10 ns
CPU 1517F-3 PN/DP	Fail-safe CPU for demanding applications and communication tasks	1	1	1	--	11 MB	2 ns
CPU 1517TF-3 PN/DP							
CPU 1518F-4 PN/DP CPU 1518F-4 PN/DP ODK	Fail-safe CPU for high-performance applications, demanding communication tasks and very short reaction times	1	1	1	1	26 MB	1 ns

Table 2- 5 Technology CPUs

CPU	Performance segment	PROFIBUS interfaces	PROFINET IO RT/IRT interfaces	PROFINET IO RT interface	PROFINET basic functionality	Work memory	Processing time for bit operations
CPU 1511T-1 PN	Technology CPU for small to mid-range applications	--	1	--	--	1.23 MB	60 ns
CPU 1515T-2 PN	Technology CPU for mid-range to large applications	--	1	1	--	3.75 MB	30 ns
CPU 1517T-3 PN/DP	Technology CPU for complex applications and communication tasks	1	1	1	--	11 MB	2 ns
CPU 1517TF-3 PN/DP	This CPU is described in the fail-safe CPUs						

### Performance segments of compact CPUs

The compact CPUs can be used for smaller to mid-range applications and have an integrated analog and digital on-board I/O as well as integrated technology functions. The following table shows the specific properties of the Compact CPUs.

	CPU 1511C-1 PN	CPU 1512C-1 PN
Integrated analog inputs/outputs	5 inputs/2 outputs	5 inputs/2 outputs
Integrated digital inputs/outputs	16 inputs/16 outputs	32 inputs/32 outputs
High-speed counters	6	6
Pulse generators <ul style="list-style-type: none"> <li>• PWM (pulse-width modulation)</li> <li>• PTO (Pulse Train Output or stepper motor control)</li> <li>• Frequency output</li> </ul>	4 (PTOx/PWMx)	4 (PTOx/PWMx)

### Integrated technological functions

The CPUs of the SIMATIC S7-1500 support motion control functions. STEP 7 offers blocks standardized according to PLCopen for configuring and connecting a drive to the CPU. Motion Control supports speed-controlled, positioning and synchronous axes (synchronizing without specification of the synchronous position) as well as external encoders, cams, cam tracks and measuring inputs.

The CPUs of the SIMATIC S7-1500T support advanced motion control functions in addition to the motion control functions offered by the standard CPUs. Additional motion control functions are absolute synchronous axes (synchronization with specification of synchronous position) and the cam.

For effective commissioning, diagnostics and fast optimization of drives and controls, the SIMATIC S7-1500 controller family offers extensive trace functions for all CPU tags.

In addition to drive integration, the SIMATIC S7-1500 has a PID compact closed-loop controller; easy-to-configure blocks allow automatic optimization of the controller parameters for optimized control quality.

Technology modules also implement functions such as high-speed counting, position detection and measuring functions and pulse generators (PWM and frequency output). In compact CPU 1511C-1 PN and CPU 1512C-1 PN CPUs, these functions are already integrated and require no additional technology modules.

SIWAREX is a versatile and flexible weighing module, which you can use as a static scale for operation.

Due to the supported technology functions, the CPUs are suitable for controlling pumps, fans, mixers, conveyor belts, lifting platforms, gate control systems, building management systems, synchronized axes, etc.

## Security Integrated

In conjunction with STEP 7, each CPU offers password-based know-how protection against unauthorized reading out or modification of the program blocks.

Copy protection provides reliable protection against unauthorized reproduction of program blocks. With copy protection, individual blocks on the SIMATIC memory card can be tied to its serial number so that the block can only be run if the configured memory card is inserted into the CPU.

In addition, you can assign various access rights to different user groups in the controller using four different authorization levels.

Improved manipulation protection allows changed or unauthorized transfers of engineering data to be detected by the controller.

The use of an Ethernet CP (CP 1543-1) provides you with additional access protection through a firewall or possibilities to establish secure VPN connections.

## Safety Integrated

The fail-safe CPUs are intended for users who want to implement demanding standard and fail-safe applications both centrally and decentrally.

These fail-safe CPUs allow the processing of standard and safety programs on a single CPU. This allows fail-safe data to be evaluated in the standard user program. The integration also provides the system advantages and the extensive functionality of SIMATIC for fail-safe applications.

The fail-safe CPUs are certified for use in safety mode up to:

- Safety class (Safety Integrity Level) SIL 3 according to IEC 61508:2010
- Performance Level (PL) e and Category 4 according to ISO 13849-1:2006 or according to EN ISO 13849-1:2008

Additional password protection for F-configuration and F-program is set up for IT security.

## Design and handling

All CPUs of the SIMATIC S7-1500 product series feature a display with plain text information. The display provides the user with information on the order numbers, firmware version, and serial number of all connected modules. In addition, the IP address of the CPU and other network settings can be adapted locally without a programming device. Error messages are immediately shown on the display in plain text, thus helping customers to reduce downtimes.

Uniform front connectors for all modules and integrated potential bridges for flexible formation of potential groups simplifies storage. Additional components such as circuit breakers, relays, etc., can be installed quickly and easily, since a DIN rail is implemented in the rail of the S7-1500. The CPUs of the SIMATIC S7-1500 product series can be expanded centrally and in a modular fashion with signal modules. Space-saving expansion enables flexible adaptation to each application.

The system cabling for digital signal modules enables fast and clear connection to sensors and actuators from the field (fully modular connection consisting of front connector modules, connection cables and I/O modules), as well as easy wiring inside the control cabinet (flexible connection consisting of front connectors with assembled single conductors).

## System diagnostics and alarms

Integrated system diagnostics is activated by default for the CPUs. The different types of diagnostics are configured instead of programmed. System diagnostics information is shown uniformly and in plain text on the display of the CPU, in STEP 7, on the HMI and on the Web server, even for alarms related to drives. This information is available in RUN mode, but also in STOP mode of the CPU. The diagnostic information is updated automatically when you configure new hardware components.

The CPU is available as a central interrupt server for 3 languages. The CPU, STEP 7 and your HMI guarantee data consistency without additional engineering steps. The maintenance work is easier.

## 2.3 How it works

### Principle of operation

The CPU contains the operating system and executes the user program. The user program is located on the SIMATIC memory card and is processed in the work memory of the CPU.

The connection to the process is centralized or distributed via PROFINET or PROFIBUS with I/O modules.

The PROFINET interfaces on the CPU allow simultaneous communication with PROFINET devices, PROFINET controllers, HMI devices, programming devices, other controllers and other systems. CPU 1513-1 PN supports operation as an IO controller and I-device.

## 2.4 Properties

### Article number

6ES7513-1AL01-0AB0

### View of the module

The following figure shows the CPU 1513-1 PN.



Figure 2-1 CPU 1513-1 PN

---

### Note

#### Protective film

Note that a protective film is attached to the display of the CPU when shipped from the factory. Remove the protective film if necessary.

---

## Properties

The CPU 1513-1 PN has the following technical properties:

- Communication:

- Interfaces

CPU 1513-1 PN has an interface.

The **1st PROFINET interface** (X1 P1, X1 P2) has two ports. In addition to PROFINET basic functionality, it also supports PROFINET IO RT (real-time) and IRT (isochronous real-time). PROFINET IO communication or real-time settings can be configured.

Port 1 and port 2 can also be used as ring ports for the configuration of redundant ring structures in Ethernet.

The basic functionality of PROFINET supports HMI communication, communication with the configuration system, communication with a higher-level network (backbone, router, Internet) and communication with another machine or automation cell.

- OPC UA

With OPC UA, data is exchanged via an open and vendor-neutral communication protocol. The CPU, as OPC UA server, can communicate with OPC UA clients such as HMI panels, SCADA systems, etc.

- Integrated Web server:

A Web server is integrated in the CPU. You can read out the following information with the Web server:

- Start page with general CPU information
- Identification information
- Contents of the diagnostics buffer
- Query of module states
- Firmware update
- Alarms (without acknowledgment option)
- Information about communication
- PROFINET topology
- Tag status, writing tags
- Watch tables
- Memory usage
- User pages
- Data logs (if used)
- Online backup and restoration of the configuration.
- Diagnostic information for the motion control technology objects
- Display of trace recording stored on the SIMATIC memory card
- Readout service data
- Basic Web pages
- Display of the Web server in 3 project languages, for example, comments and message texts
- Recipes
- User-defined Web pages

- Integrated technology:
  - Motion Control

The Motion Control functionality uses technology objects to support speed-controlled axes, positioning axes, synchronous axes, external encoders, cams, cam tracks and measuring inputs, as well as PLCopen blocks for programming the motion control functionality.

You can find a detailed description of the use of Motion Control and its configuration in the S7-1500 Motion Control (<http://support.automation.siemens.com/WW/view/en/109739589>) function manual.

You can also use the TIA Selection Tool (<http://w3.siemens.com/mcms/topics/en/simatic/tia-selection-tool>) or the SIZER (<http://w3.siemens.com/mcms/mc-solutions/en/engineering-software/drive-design-tool-sizer/Pages/drive-design-tool-sizer.aspx>) to create or configure axes.
  - Integrated closed-loop control functionality
    - PID Compact (continuous PID controller)
    - PID 3Step (step controller for integrating actuators)
    - PID Temp (temperature controller for heating and cooling with two separate actuators)
- Trace functionality:
  - The trace functionality supports troubleshooting and optimization of the user program. You can find additional information on the trace functionality in the Using the Trace and Logic Analyzer (<http://support.automation.siemens.com/WW/view/en/64897128>) function manual.
- Integrated system diagnostics:
  - The alarms for the system diagnostics are automatically created by the system and displayed on a PG/PC, HMI device, Web server or the integrated display. System diagnostics information is also available when the CPU is in STOP mode.

- Integrated security:
  - Know-how protection  
The know-how protection protects user blocks against unauthorized access and modifications.
  - Copy protection  
Copy protection links user blocks to the serial number of the SIMATIC memory card or to the serial number of the CPU. User programs cannot run without the corresponding SIMATIC memory card or CPU.
  - Access protection  
Extended access protection provides high-quality protection against unauthorized configuration changes. You can use authorization levels to assign separate rights to different user groups.
  - Integrity protection  
The system protects the data transferred to the CPU against manipulation. The CPU detects erroneous or manipulated engineering data.
- Additional functions:
  - PROFIenergy  
You can find information on the topic of "PROFIenergy" in the PROFINET function manual (<https://support.industry.siemens.com/cs/ww/en/view/49948856>) and in the PROFINET specification on the Internet (<http://www.profibus.com>).
  - Shared device  
You can find information on the topic of "Shared device" in the PROFINET function manual (<https://support.industry.siemens.com/cs/ww/en/view/49948856>).
  - Configuration control  
You can find information on the topic of "Configuration control" in the S7-1500, ET 200MP (<http://support.automation.siemens.com/WW/view/en/59191792>) system manual.
  - Isochronous mode  
You can find information about the "Isochronous mode" topic in the PROFINET (<https://support.industry.siemens.com/cs/ww/en/view/49948856>) function manual.

## Reference

You will find additional information on the topic of "Integrated security/Access protection" in the S7-1500, ET 200MP (<http://support.automation.siemens.com/WW/view/en/59191792>) system manual.

## 2.5 Operating and display elements

### 2.5.1 Front view of the module with closed front panel

The following figure shows the front view of the CPU 1513-1 PN.

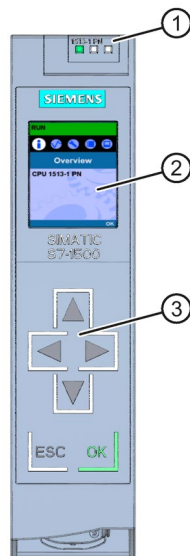

- ① LEDs for the current operating mode and diagnostics status of the CPU
- ② Display
- ③ Operator control buttons

Figure 2-2 View of the CPU 1513-1 PN (with front panel) - front

---

#### Note

##### Temperature range for display

To increase its service life, the display switches off at a temperature below the permitted operating temperature of the device. When the display cools down, it automatically switches itself on again. When the display is switched off, the LEDs continue to show the status of the CPU.

For more information on the temperatures at which the display switches itself on and off, refer to the Technical specifications (Page 33).

---

### Removing and attaching the front panel with display

You can remove and attach the front panel with display during operation.

<b>⚠ WARNING</b>
<b>Personal injury and damage to property may occur</b>
If you remove or attach the front panel of an S7-1500 automation system during operation, personal injury or damage to property can occur in zone 2 hazardous areas.
Before you remove or fit the front panel, always switch off the power supply to the S7-1500 automation system in hazardous area zone 2. The CPU maintains its operating mode.

### Locking the front panel

You can lock the front panel to protect your CPU against unauthorized access.

You can attach a security seal or a padlock with a diameter of 3 mm to the front panel.

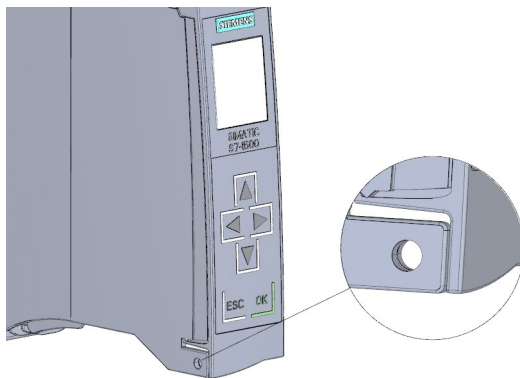

Figure 2-3 Locking latch on the CPU

In addition to the mechanical lock, you can also block access to a password-protected CPU on the display (local lock) and assign a password for the display. You can find additional information on the display, configurable protection levels and local locks in the S7-1500/ET 200MP (<http://support.automation.siemens.com/WW/view/en/59191792>) system manual.

### Reference

You will find detailed information on the individual display options, a training course and a simulation of the available menu commands in the SIMATIC S7-1500 Display Simulator ([http://www.automation.siemens.com/salesmaterial-as/interactive-manuals/getting-started\\_simatic-s7-1500/disp\\_tool/start\\_en.html](http://www.automation.siemens.com/salesmaterial-as/interactive-manuals/getting-started_simatic-s7-1500/disp_tool/start_en.html)).

## 2.5.2 Front view of the module without front panel

The following figure shows the operator controls and connection elements of the CPU 1513-1 PN.

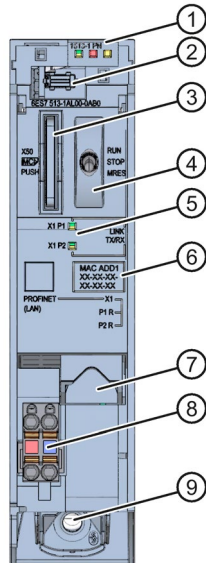

- ① LEDs for the current operating mode and diagnostic status of the CPU
- ② Display connector
- ③ Slot for the SIMATIC memory card
- ④ Mode selector
- ⑤ LEDs for the 2 ports of the PROFINET interface X1
- ⑥ MAC address
- ⑦ PROFINET IO interface (X1) with 2 ports
- ⑧ Connector for power supply
- ⑨ Fixing screw

Figure 2-4 View of the CPU 1513-1 PN (without front panel) - front

### 2.5.3 Rear view of the module

The following figure shows the connection elements on the back of the CPU 1513-1 PN.

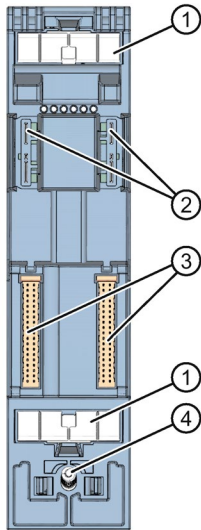

- ① Shield contact surface
- ② Plug-in connection for power supply
- ③ Plug-in connection for backplane bus
- ④ Fastening screw

Figure 2-5 View of the CPU 1513-1 PN - rear

## 2.6 Mode selector switch

Use the mode switch to set the CPU operating mode.

The following table shows the position of the switch and the corresponding meaning.

Table 2-6 Mode switch settings

Position	Meaning	Explanation
RUN	RUN mode	The CPU is executing the user program.
STOP	STOP mode	The user program is not being executed.
MRES	Memory reset	Position for CPU memory reset.

## Connecting up

This section provides information on the terminal assignment of the individual interfaces and the block diagram of the CPU 1513-1 PN.

### 24 V DC supply voltage (X80)

The connector for the power supply is plugged in when the CPU ships from the factory.

The following table shows the pin assignment for a 24 V DC power supply.

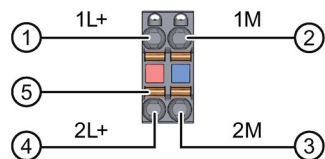

- ① +24 V DC of the supply voltage
- ② Ground of the supply voltage
- ③ Ground of the supply voltage for loop-through (maximum of 10 A permitted)
- ④ +24 V DC of the supply voltage for loop-through (maximum of 10 A permitted)
- ⑤ Spring opener (one spring opener per terminal)

Bridged internally:

- ① and ④
- ② and ③

Figure 3-1 Supply voltage connection

If the CPU is supplied by a system power supply, it is not necessary to connect the 24 V supply.

### PROFINET interface X1 with 2-port switch (X1 P1 R and X1 P2 R)

The assignment corresponds to the Ethernet standard for an RJ45 plug.

- When autonegotiation is deactivated, the RJ45 socket is allocated as a switch (MDI-X).
- When autonegotiation is activated, autocrossing is in effect and the RJ45 socket is allocated either as data terminal equipment (MDI) or a switch (MDI-X).

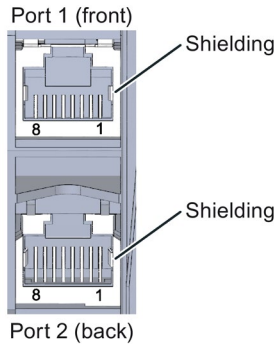

### Reference

You can find additional information on the topics of "Connecting the CPU" and "Accessories/spare parts" in the S7-1500, ET 200MP (<http://support.automation.siemens.com/WW/view/en/59191792>) system manual.

### Assignment of the MAC addresses

The CPU 1513-1 PN has a PROFINET interface with two ports. The PROFINET interface itself has a MAC address, and each of the two PROFINET ports has its own MAC address. The CPU 1513-1 PN therefore has three MAC addresses in total.

The MAC addresses of the PROFINET ports are needed for the LLDP protocol, for example for the neighborhood discovery function.

The number range of the MAC addresses is sequential. The first and last MAC address are lasered on the rating plate on the right side of each CPU 1513-1 PN.

The table below shows how the MAC addresses are assigned.

Table 3- 1 Assignment of the MAC addresses

	Assignment	Labeling
<b>MAC address 1</b>	PROFINET interface X1 (visible in STEP 7 for accessible devices)	<ul style="list-style-type: none"> <li>• Front, lasered</li> <li>• Right side, lasered (start of number range)</li> </ul>
<b>MAC address 2</b>	Port X1 P1 R (required for LLDP, for example)	<ul style="list-style-type: none"> <li>• Front and right side, not lasered</li> </ul>
<b>MAC address 3</b>	Port X1 P2 R (required for LLDP, for example)	<ul style="list-style-type: none"> <li>• Front, not lasered</li> <li>• Right side, lasered (end of number range)</li> </ul>

## Block diagram

The following figure shows the block diagram of the CPU 1513-1 PN.

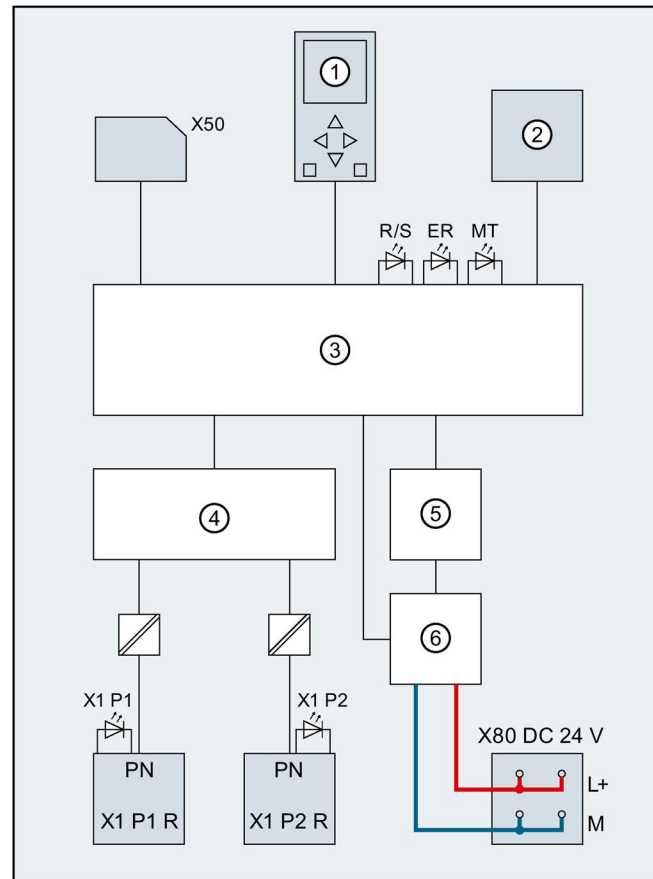

①	Display	PN X1 P1 R	PROFINET interface X1 Port 1
②	RUN/STOP/MRES mode selector	PN X1 P2 R	PROFINET interface X1 Port 2
③	Electronics	L+	24 V DC supply voltage
④	PROFINET 2-port switch	M	Ground
⑤	Backplane bus interface	R/S	RUN/STOP LED (yellow/green)
⑥	Internal supply voltage	ER	ERROR LED (red)
X50	SIMATIC memory card	MT	MAINT LED (yellow)
X80 24 V DC	Infeed of supply voltage	X1 P1, X1 P2	LED Link TX/RX

Figure 3-2 Block diagram of the CPU 1513-1 PN

# Interrupts, error messages, diagnostics and system alarms

# 4

The status and error displays of the CPU 1513-1 PN are described below.

You will find additional information on "Interrupts" in the STEP 7 online help.

You can find additional information on the topics of "Diagnostics" and "System alarms" in the Diagnostics (<http://support.automation.siemens.com/WW/view/en/59192926>) function manual.

## 4.1 Status and error display of the CPU

### LED display

The figure below shows the CPU 1513-1 PN LEDs.

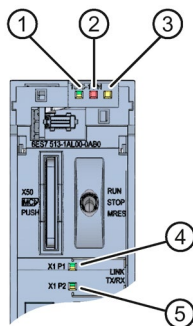





































- ① RUN/STOP LED (yellow/green LED)
- ② ERROR LED (red LED)
- ③ MAINT LED (yellow LED)
- ④ LINK RX/TX LED for port X1 P1 (yellow/green LED)
- ⑤ LINK RX/TX LED for port X1 P2 (yellow/green LED)

Figure 4-1 LED display of the CPU 1513-1 PN (without front panel)

### Meaning of the RUN/STOP, ERROR and MAINT LEDs

The CPU 1513-1 PN has three LEDs to signal the current operating status and diagnostics status. The following table shows the meaning of the various combinations of colors for the RUN/STOP, ERROR and MAINT LEDs.

Table 4- 1 Meaning of the LEDs





RUN/STOP LED	ERROR LED	MAINT LED	Meaning
 LED off	 LED off	 LED off	Missing or insufficient power supply on the CPU.
 LED off	 LED flashes red	 LED off	An error has occurred.
 LED lit green	 LED off	 LED off	CPU is in RUN mode.
 LED lit green	 LED flashes red	 LED off	A diagnostics event is pending.
 LED lit green	 LED off	 LED lit yellow	Maintenance demanded for the plant. The affected hardware must be checked/replaced within a short period of time.
			Active Force job
			PROFenergy pause
 LED lit green	 LED off	 LED flashes yellow	Maintenance required for the plant. The affected hardware must be checked/replaced within a foreseeable period of time.
			Bad configuration
 LED lit yellow	 LED off	 LED flashes yellow	Firmware update successfully completed.
 LED lit yellow	 LED off	 LED off	CPU is in STOP mode.
 LED lit yellow	 LED flashes red	 LED flashes yellow	The program on the SIMATIC memory card is causing an error.
			CPU defective
 LED flashes yellow	 LED off	 LED off	CPU is performing internal activities during STOP, e.g. startup after STOP.
			Download of the user program from the SIMATIC memory card
 LED flashes yellow/green	 LED off	 LED off	Startup (transition from RUN → STOP)
 LED flashes yellow/green	 LED flashes red	 LED flashes yellow	Startup (CPU booting)
			Test of LEDs during startup, inserting a module.
			LED flashing test

4.1 Status and error display of the CPU

**Meaning of LINK RX/TX LED**

Each port has a LINK RX/TX-LED. The table below shows the various "LED scenarios" of ports for the CPU 1513-1 PN.

Table 4- 2 Meaning of the LEDs

LINK TX/RX LED	Meaning
 LED off	There is no Ethernet connection between the PROFINET interface of the PROFINET device and the communication partner. No data is currently being sent/received via the PROFINET interface. There is no LINK connection.
 LED flashes green	The "LED flashing test" is being performed.
 LED lit green	There is an Ethernet connection between the PROFINET interface of your PROFINET device and a communication partner.
 LED flickers yellow	Data is currently being received from or sent to a communications partner on Ethernet via the PROFINET interface of the PROFINET device.

# Technical specifications

6ES7513-1AL01-0AB0	
<b>General information</b>	
Product type designation	CPU 1513-1 PN
Hardware function version	FS03
Firmware version	V2.0
<b>Engineering with</b>	
STEP 7 TIA Portal can be configured/integrated as of version	V14
<b>Configuration control</b>	
Via data record	Yes
<b>Display</b>	
Screen diagonal (cm)	3.45 cm
<b>Operator controls</b>	
Number of buttons	6
Mode selector	1
<b>Supply voltage</b>	
Type of supply voltage	24 V DC
Low limit of permitted range (DC)	19.2 V
High limit of permitted range (DC)	28.8 V
Reverse polarity protection	Yes
<b>Power and voltage failure buffering</b>	
Power/voltage failure buffer time	5 ms
<b>Input current</b>	
Current consumption (rated value)	0.7 A
Inrush current, max.	1.9 A; rated value
$I^2t$	0.02 A <sup>2</sup> s
<b>Power</b>	
Power consumption from the backplane bus (balanced)	5.5 W
Incoming power to the backplane bus	10 W
<b>Power loss</b>	
Power loss, typ.	5.7 W
<b>Memory</b>	
Number of slots for SIMATIC memory card	1
SIMATIC memory card required	Yes
<b>Work memory</b>	
Integrated (for program)	300 KB
Integrated (for data)	1.5 MB

<b>6ES7513-1AL01-0AB0</b>	
<b>Load memory</b>	
Plug-in (SIMATIC memory card), max.	32 GB
<b>Buffering</b>	
Maintenance-free	Yes
<b>CPU processing times</b>	
For bit operations, typ.	40 ns
For word operations, typ.	48 ns
For fixed-point arithmetic, typ.	64 ns
For floating-point arithmetic, typ.	256 ns
<b>CPU blocks</b>	
Number of elements (total)	2000; blocks (OB/FB/FC/DB) and UDTs
<b>DB</b>	
Number range	1 ... 60 999; divided into: Number range available for the user: 1 ... 59 999 and number range for DBs generated by SFC 86: 60 000 ... 60 999
Size, max.	1.5 MB; the maximum size of the DB is 64 KB with non-optimized block access
<b>FB</b>	
Number range	0 ... 65 535
Size, max.	300 KB
<b>FC</b>	
Number range	0 ... 65 535
Size, max.	300 KB
<b>OB</b>	
Size, max.	300 KB
Number of free-cycle OBs	100
Number of time-of-day interrupt OBs	20
Number of time-delay interrupt OBs	20
Number of cyclic interrupt OBs	20; with minimum OB 3x cycle of 500 µs
Number of hardware interrupt OBs	50
Number of DPV1 interrupt OBs	3
Number of isochronous mode OBs	1
Number of technology synchronous interrupt OBs	2
Number of restart OBs	100
Number of asynchronous error OBs	4
Number of synchronous error OBs	2
Number of diagnostic interrupt OBs	1
<b>Nesting depth</b>	
Per priority class	24
<b>Counters, timers and their retentivity</b>	
<b>S7 counters</b>	
Quantity	2048
Retentivity	Yes
• Adjustable	Yes

	6ES7513-1AL01-0AB0
<b>IEC counters</b>	
Quantity	Unlimited (limited only by work memory)
Retentivity	
• Adjustable	Yes
<b>S7 timers</b>	
Quantity	2048
Retentivity	
• Adjustable	Yes
<b>IEC timers</b>	
Quantity	Unlimited (limited only by work memory)
Retentivity	
• Adjustable	Yes
<b>Data areas and their retentivity</b>	
Total retentive data area (including timers, counters, bit memories), max.	128 KB; in total; for bit memories, timers, counters, DBs and technological data (axes), usable retentive memory: 88 KB
<b>Bit memory</b>	
Number, max.	16 KB
Number of clock memory bits	8; 8 clock memory bits, grouped in one clock memory byte
<b>Data blocks</b>	
Retentivity adjustable	Yes
Retentivity preset	No
<b>Local data</b>	
Per priority class, max.	64 KB; max. 16 KB per block
<b>Address area</b>	
Number of I/O modules	2048; max. number of modules/submodules
<b>I/O address area</b>	
Inputs	32 KB; all inputs are in the process image
Outputs	32 KB; all outputs are in the process image
Of which per integrated IO subsystem	
• Inputs (volume)	8 KB
• Outputs (volume)	8 KB
Of which per CM/CP	
• Inputs (volume)	8 KB
• Outputs (volume)	8 KB
<b>Process image partitions</b>	
Number of process image partitions, max.	32

<b>6ES7513-1AL01-0AB0</b>	
<b>Hardware configuration</b>	
Number of distributed IO systems	32; a distributed IO system is understood to mean the integration of distributed I/O via PROFINET or PROFIBUS communication modules as well as the connection of I/O via AS-i master modules or links (e.g. IE/PB link)
<b>Number of DP masters</b>	
Via CM	6; a maximum of 6 CMs (PROFINET + PROFIBUS) can be inserted in total
<b>Number of IO controllers</b>	
Integrated	1
Via CM	6; a maximum of 6 CMs (PROFINET + PROFIBUS) can be inserted in total
<b>Rack</b>	
Modules per rack, max.	32; CPU + 31 modules
Number of rows, max.	1
<b>PtP CM</b>	
Number of PtP CMs	The number of PtP CMs that can be connected is only limited by the available slots
<b>Time</b>	
<b>Clock</b>	
Type	Hardware clock
Backup duration	6 wk; at 40 °C ambient temperature, typ.
Deviation per day, max.	10 s; typ.: 2 s
<b>Operating hours counter</b>	
Quantity	16
<b>Time-of-day synchronization</b>	
Supported	Yes
in AS, Master	Yes
in AS, Slave	Yes
On Ethernet via NTP	Yes
<b>Interfaces</b>	
Number of PROFINET interfaces	1
<b>1st interface</b>	
<b>Interface hardware</b>	
Number of ports	2
Integrated switch	Yes
RJ45 (Ethernet)	Yes; X1
<b>Protocols</b>	
PROFINET IO controller	Yes
PROFINET IO device	Yes
SIMATIC communication	Yes
Open IE communication	Yes
Web server	Yes
Media redundancy	Yes

	6ES7513-1AL01-0AB0
<b>PROFINET IO controller</b>	
Services	
• PG/OP communication	Yes
• S7 routing	Yes
• Isochronous mode	Yes
• Open IE communication	Yes
• IRT	Yes
• MRP	Yes; as MRP redundancy manager and/or MRP client; max. number of devices in the ring: 50
• MRPD	Yes; requirement: IRT
• Prioritized startup	Yes; max. 32 PROFINET devices
• Number of connectable IO devices, max.	128
• of these, IO devices with IRT, max.	64
• Number of connectable IO devices for RT, max.	128
• of these, in a line topology, max.	128
• Number of IO devices that can be activated/deactivated simultaneously, max.	8; in total over all interfaces
• Number of IO devices per tool, max.	8
• Update times	The minimum value of the update time also depends on the communication component set for PROFINET IO, on the number of IO devices, and on the quantity of configured user data.
Update time with IRT	
• for send clock of 250 µs	250 µs to 4 ms; note: with IRT with isochronous mode, the minimum update time of 500 µs of the isochronous OB is crucial
• With send clock of 500 µs	500 µs to 8 ms
• With send clock of 1 ms	1 ms to 16 ms
• with send clock of 2 ms	2 ms to 32 ms
• with send clock of 4 ms	4 ms to 64 ms
• with IRT and "odd" send clock parameter assignment	Update time = set "odd" send clock (any multiple of 125 µs: 375 µs, 625 µs to 3 875 µs)

	6ES7513-1AL01-0AB0
Update time with RT	
<ul style="list-style-type: none"> <li>• for send clock of 250 µs</li> <li>• With send clock of 500 µs</li> <li>• With send clock of 1 ms</li> <li>• with send clock of 2 ms</li> <li>• with send clock of 4 ms</li> </ul>	250 µs to 128 ms 500 µs to 256 ms 1 ms to 512 ms 2 ms to 512 ms 4 ms to 512 ms
<b>PROFINET IO device</b>	
Services	
<ul style="list-style-type: none"> <li>• PG/OP communication</li> <li>• S7 routing</li> <li>• Isochronous mode</li> <li>• Open IE communication</li> <li>• IRT</li> <li>• MRP</li> <li>• MRPD</li> <li>• PROFINergy</li> <li>• Shared device</li> <li>• Number of IO controllers with shared device, max.</li> </ul>	Yes Yes No Yes Yes Yes; requirement: IRT Yes Yes 4
<b>Interface hardware</b>	
<b>RJ 45 (Ethernet)</b>	
100 Mbps	Yes
Autonegotiation	Yes
Autocrossing	Yes
Industrial Ethernet status LED	Yes
<b>Protocols</b>	
<b>Number of connections</b>	
Number of connections, max.	128; via integrated interfaces of the CPU and connected CPs/CMs
Number of connections reserved for ES/HMI/Web	10
Number of connections via integrated interfaces	88
Number of S7 routing connections	16

	6ES7513-1AL01-0AB0
<b>PROFINET IO controller</b>	
Services	
• PG/OP communication	Yes
• S7 routing	Yes
• Isochronous mode	Yes
• Open IE communication	Yes
• IRT	Yes
• MRP	Yes; as MRP redundancy manager and/or MRP client; max. number of devices in the ring: 50
• MRPD	Yes; requirement: IRT
• PROFIenergy	Yes
• Prioritized startup	Yes; max. 32 PROFINET devices
• Number of connectable IO devices, max.	128; a total of up to 512 distributed I/O devices can be connected via AS-i, PROFIBUS or PROFINET
• of these, IO devices with IRT, max.	64
• Number of connectable IO devices for RT, max.	128
• of these in a line, max.	128
• Number of IO devices that can be enabled/disabled simultaneously, max.	8; in total over all interfaces
• Number of IO devices per tool, max.	8
• Update times	Minimum value of update time also depends on the communication allocation setting for PROFINET IO, the number of IO devices and the amount of configured user data
<b>SIMATIC communication</b>	
S7 communication, as server	Yes
S7 communication, as client	Yes
User data per job, max.	See online help (S7 communication, user data size)
<b>Open IE communication</b>	
TCP/IP	Yes
• Data length, max.	64 KB
• Multiple passive connections per port, supported	Yes
ISO-on-TCP (RFC1006)	Yes
• Data length, max.	64 KB
UDP	Yes
• Data length, max.	1472 bytes
DHCP	No

	6ES7513-1AL01-0AB0
SNMP	Yes
DCP	Yes
LLDP	Yes
<b>Web server</b>	
HTTP	Yes; standard and user-defined sites
HTTPS	Yes; standard and user-defined sites
<b>OPC UA</b>	
OPC UA server	Yes; Data Access (Read, Write, Subscribe), Runtime license required
<ul style="list-style-type: none"> <li>• Application authentication</li> <li>• Security Policies</li> </ul>	Yes  Available Security Policies: None, Basic128Rsa15, Basic256Rsa15, Basic256Sha256
<ul style="list-style-type: none"> <li>• User authentication</li> </ul>	"Anonymous" or with user name and password
<b>Additional protocols</b>	
MODBUS	Yes; MODBUS TCP
<b>Media redundancy</b>	
Switchover time in the case of cable break, typ.	200 ms; with MRP; bumpless with MRPD
Number of devices in the ring, max.	50
<b>Isochronous mode</b>	
Isochronous mode (application synchronized up to terminal)	Yes; with minimum OB 6x cycle of 500 µs
Constant bus cycle time	Yes
<b>S7 signaling functions</b>	
Number of stations that can be logged in for signaling functions, max.	32
Block-related alarms	Yes
Number of configurable interrupts, max.	5000
Number of simultaneously active interrupts in interrupt pool	
<ul style="list-style-type: none"> <li>• Number of reserved user interrupts</li> </ul>	300
<ul style="list-style-type: none"> <li>• Number of reserved interrupts for system diagnostics</li> </ul>	100
<ul style="list-style-type: none"> <li>• Number of reserved interrupts for motion control technology objects</li> </ul>	80
<b>Test/commissioning functions</b>	
Joint commissioning (Team Engineering)	Yes; parallel online access possible for up to 5 engineering systems
Status block	Yes; up to 8 simultaneously (in total over all ES clients)
Single-step	No

<b>6ES7513-1AL01-0AB0</b>	
<b>Status/modify</b>	
Status/modify tag	Yes
Tags	Inputs/outputs, bit memory, DB, peripheral inputs/outputs, timers, counters
Number of tags, max.	
• Of which are status tags, max.	200; per job
• Of which are modify tags, max.	200; per job
<b>Force</b>	
Forcing, tags	Peripheral inputs/outputs
Number of tags, max.	200
<b>Diagnostics buffer</b>	
Available	Yes
Number of entries, max.	1000
• Of which are power failure-proof	500
<b>Traces</b>	
Number of configurable traces	4; up to 512 KB data possible per trace
<b>Interrupts/diagnostics/status information</b>	
<b>Diagnostics display LED</b>	
RUN/STOP LED	Yes
ERROR LED	Yes
MAINT LED	Yes
Connection display LINK TX/RX	Yes
<b>Supported technology objects</b>	
Motion control	Yes; note: the number of axes affects the cycle time of the PLC program; selection guide via the TIA Selection Tool or SIZER
• Number of available motion control resources for technology objects (except cams)	800
• required Motion Control resources	
– per speed-controlled axis	40
– per positioning axis	80
– per synchronous axis	160
– per external encoder	80
– per output cam	20
– per cam track	160
– per measuring input	40
• Positioning axis	
– Number of positioning axes with motion control cycle of 4 ms (typical value)	3; with 40 % CPU utilization by Motion Control
– Number of positioning axes with motion control cycle of 8 ms (typical value)	8; with 40 % CPU utilization by Motion Control

<b>6ES7513-1AL01-0AB0</b>	
Controller	
<ul style="list-style-type: none"> <li>• PID_Compact</li> <li>• PID_3Step</li> <li>• PID temp</li> </ul>	<p>Yes; universal PID controller with integrated optimization</p> <p>Yes; PID controller with integrated optimization for valves</p> <p>Yes; PID controller with integrated optimization for temperature</p>
Counting and measuring	
<ul style="list-style-type: none"> <li>• High-speed counter</li> </ul>	Yes
<b>Ambient conditions</b>	
<b>Ambient temperature during operation</b>	
Horizontal mounting position, min.	0 °C
Horizontal mounting position, max.	60 °C; display: 50 °C, the display is switched off at an operating temperature of typically 50 °C
Vertical mounting position, min.	0 °C
Vertical mounting position, max.	40 °C; display: 40 °C, the display is switched off at an operating temperature of typically 40 °C
<b>Ambient temperature during storage/transport</b>	
Min.	-40 °C
Max.	70 °C
<b>Configuring</b>	
<b>Programming</b>	
Programming language	
<ul style="list-style-type: none"> <li>• LAD</li> <li>• FBD</li> <li>• STL</li> <li>• SCL</li> <li>• GRAPH</li> </ul>	<p>Yes</p> <p>Yes</p> <p>Yes</p> <p>Yes</p> <p>Yes</p>
<b>Know-how protection</b>	
User program protection	Yes
Copy protection	Yes
Block protection	Yes
<b>Access protection</b>	
Password for display	Yes
Protection level: Write protection	Yes
Protection level: Read/write protection	Yes
Protection level: Complete protection	Yes
<b>Cycle-time monitoring</b>	
Low limit	Adjustable minimum cycle time
High limit	Adjustable maximum cycle time

6ES7513-1AL01-0AB0	
<b>Dimensions</b>	
Width	35 mm
Height	147 mm
Depth	129 mm
<b>Weights</b>	
Weight, approx.	430 g

### General technical specifications

You can find information on the general technical specifications, such as standards and approvals, electromagnetic compatibility, protection class, etc., in the S7-1500, ET 200MP (<http://support.automation.siemens.com/WW/view/en/59191792>) system manual.

## Dimensional drawing

This section includes a dimensional drawing of the module on a mounting rail and a dimensional drawing with the front panel open. Always observe the specified dimensions for installation in cabinets, control rooms, etc.

### Dimensional drawings for CPU 1513-1 PN

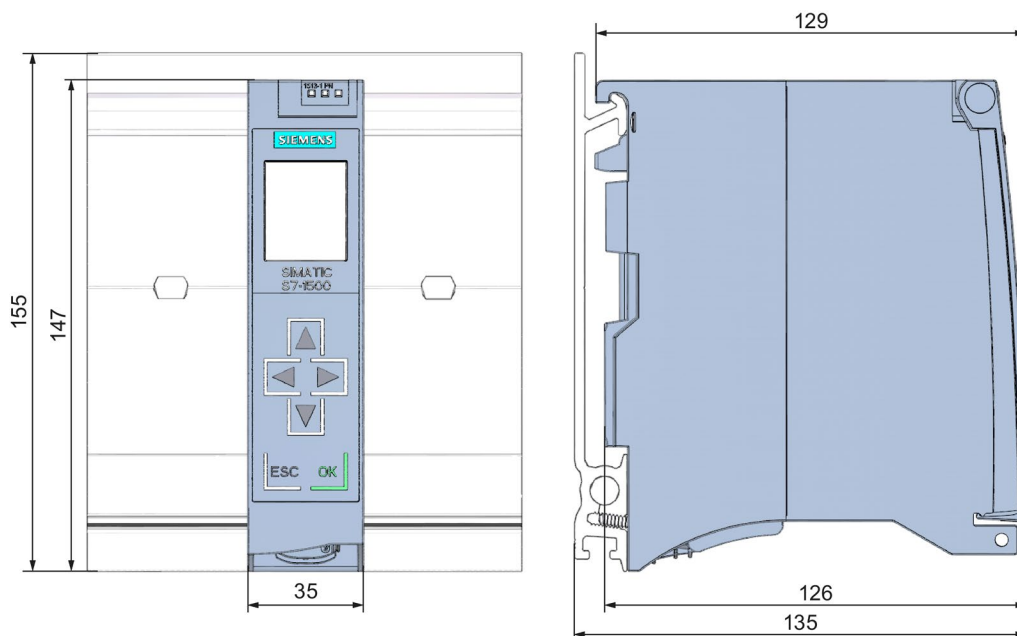

Figure A-1 Dimensional drawing of CPU 1513-1 PN, front and side views

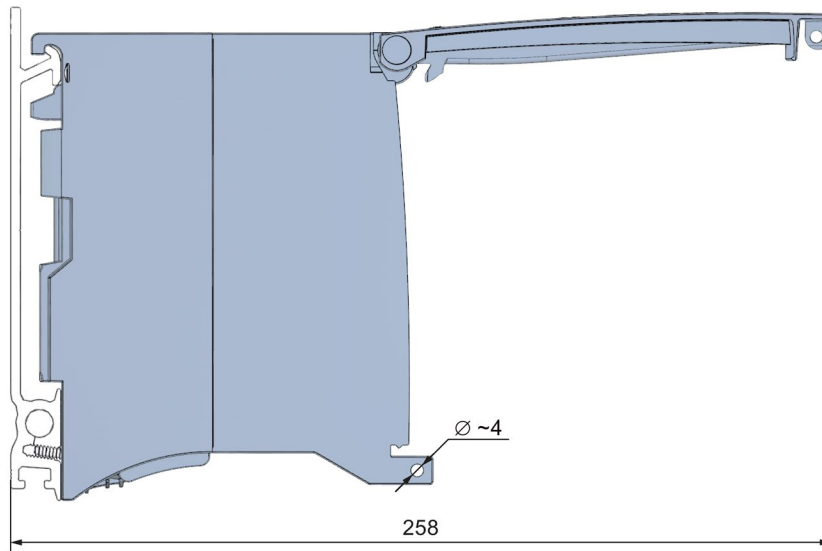

Figure A-2 Dimensional drawing of CPU 1513-1 PN, side view with front panel open