

SPECIFICATION
OIL IMMERSED TRANSFORMER
160 kVA 3Ph 50Hz
22000 – 400/230 V.

1. SPEC No : **T0160200309**

2. CUSTOMER :

3. REQUIREMENT :

Quantity	Description			
	kVA	Phase	Hz.	Voltage
1	160	3	50	22000 - 400/230

4. SCOPE :

This specification covers oil immersed transformer

Core type

Natural self - cooled

Shell type

Forced - air - cooled

Forced - oil - forced - air cooled

The transformer will be designed suitable for used

Outdoor installation

With cable end box

Indoor installation

Without cable end box

On the system voltage

3.3 kV.

12 kV.

6.6 kV.

22 kV.

11 kV.

24 kV.

33 kV.

5. STANDARD :

The transformer , all equipment and materials shall be manufactured and tested in accordance with the latest applicable standard specifications and codes in the following list :

ANSI American Nation Standards Institute Incorporated (ANSI.C57.12)

IEEE Institute of Electrical and Electronic Engineers

NEMA National Electrical Manufacture's Association

ASTM American Society of Testing Materials

VDE Regulation and DIN Standard (VDE 0532/11)

IEC International Electrotechnical Commission (Publication 60076-1 to 60076-5)

BSI British Standard Institution (BS 171-1 to 171-5)

TIS.384-2543

6. SERVICE CONDITION

The transformer and accessories shall be designed and constructed for installation the following conditions :

Altitude : up to 1000 M above sea level

Ambient : air temperature 40° C maximum
 35° C average on one day

7. RATING

High Voltage Tension : **22000** V.

Low Voltage Tension : **400/230** V.

Tapping :	Range	<input type="checkbox"/>	-4x2.5%	<input checked="" type="checkbox"/>	± 2x2.5%
	Winding	<input checked="" type="checkbox"/>	HV winding	<input type="checkbox"/>	LV winding
	Location	<input type="checkbox"/>	Adjusted inside the transformer tank	<input checked="" type="checkbox"/>	Adjusted outside the transformer tank
				<input checked="" type="checkbox"/>	On the top of the transformer cover.
				<input type="checkbox"/>	On the side of the transformer tank
HT and LT Bushing :	Accordance with			<input checked="" type="checkbox"/>	DIN 42530,42531,42539
	Mounted	<input checked="" type="checkbox"/>	On the top of the transformer cover	<input type="checkbox"/>	On the side of the transformer tank
		<input type="checkbox"/>	Inside the cable box		

Vector Group of Polarity : **Dyn11**

Frequency : 50 Hz.

Operation duty : Continuous Operation (DB)

Neutral point of the star winding will be designed for

<input checked="" type="checkbox"/>	100% accessible loading
<input type="checkbox"/>	50% accessible loading

8. LOSS AND IMPEDANCE VOLTAGE :

The guaranteed losses and impedance voltage of the offered transformer shall comply with the figures in the table below :

Rating kVA	Watt loss		Percent Impedance Voltage at 75° C
	No load loss	Load loss at 75° C	
160	360	2100	4

9. TRANSFORMER CONSTRUCTION

Tank Each transformer shall be provided with a steel case of substantial construction , which shall be oil-tight and gas tight. The tank shall be capable of withstanding , without leakage or permanent distortion , a pressure of +5 p.s.i and shall withstand continuously a vacuum of 5 p.s.i inside of the tank. The tank cover shall be provided with suitable hand holes , if required. A grounding pad shall be provided on the tank wall near the base.

Core Core shall be constructed of high quality , nonaging , high permeability silicon steel and designed to accessible loading 110% rated voltage without making injury to the transformer core. The steel shall be in thin laminations , annealed after cutting and rolled to insure smooth surface at the edges. Both sides of each sheet shall be insulated with a durable , heat resistant baked enamel or varnish. The cores shall be rigidly clamped with positive locking devices to insure adequate mechanical strength to support the windings and reduce vibration to a minimum during operation.

Windings The design , construction and treatment of winding shall give proper consideration to all service factor , such as high dielectric and mechanical strength of insulation coil characteristic , uniform electrostatic flux distribution prevention of corona formation , and minimum restriction to free oil circulation. For transformer 1000 kVA and above the completed assembly of core and coil shall be tightened rigidly with the pressure ring made injury and shall be dried in a vacuum sufficient to insure elimination of air and moisture within the insulating structure. After the drying , process , assemble shall be immediately impregnated with dry oil.

Insulation class of winding as below :

Terminal	Insulation class	Low frequency test	BIL (kV)
	(kV)	(kV)	
HV.	24	50	125
LV.	-	3.0	-
Neutral	-	3.0	-

The insulation resistance between winding and earth tested by Meggar ohm. Meter not less than 2500 Vdc

P-E not less than	1000	M ohm.
S-E not less than	1000	M ohm.
P-S not less than	1000	M ohm.

At the ambient temperature 32° C and relative humidity 80%

Bushing The bushing shall conform and be located to the requirement of the reference standard.

Basic impulse insulation level (BIL) for bushings :

HV.	125	kV
HV. Neutral	-	kV
LV.	30	kV
LV. Neutral	30	kV

Transformer oil The transformer oil shall be will filtered and the dielectric strength before filling in transformer tank is not less than 30 kV / 2.5 mm. gap as tested by the method specified by ASTM D877 or IEC 156. The dielectric strength of the sample of insulating oil taken from a new transformer shall not be less than 27 kV : when measured in accordance with ANSI Standard Method of testing Electrical Insulating Oil C59.2-1966 or equal.

Terminal Arrangement H.T. and L.T. bushings shall be equipped with solderless pad type connectors for AL. And CU.

Conductor size as follow :

Terminal	Transformer Rating kVA	Applicable to AL. and Cu. Conductors		Number Of Circuits
		Size (mm ²)	diameter (mm)	
HV.	160	35 – 120	7.5 – 12.6	1
LV.		35 – 120	7.5 – 12.9	4
Neutral		35 - 120	7.5 – 12.9	4

Tank cleaning and Painting All surfaces shall be thoroughly cleaned by chemical. Interior surface shall be finished with oil - resisting point. Exterior surface shall be painted with a primer coat and two (2) finish weather – resisting coats , Gray gloss Enamel Tys NC – G001

10. TEMPERATURE :

Average winding temperature rise by resistance method when carrying max. continuous rated capacity : 65° C

Average top oil continuous rated capacity : 60° C

Hottest spot winding temperature rise when carrying max. continuous rated capacity : 80° C

11. ACCESSORIES :

The transformer shall equipped with the following accessories :

<input checked="" type="checkbox"/>	Oil drain , filter press sampling valve.
<input checked="" type="checkbox"/>	Liquid level gauge
<input checked="" type="checkbox"/>	Upper filter press connection
<input checked="" type="checkbox"/>	Off-load tap changer
<input checked="" type="checkbox"/>	Lifting lugs.
<input checked="" type="checkbox"/>	Tank grounding provision.
<input checked="" type="checkbox"/>	Name plate.
<input type="checkbox"/>	Oil thermometer.
<input type="checkbox"/>	Dehydrating breather
<input type="checkbox"/>	Buchholz relay
<input checked="" type="checkbox"/>	Mechanical Pressure relief device
<input type="checkbox"/>	
<input type="checkbox"/>	
<input type="checkbox"/>	

Other standard accessories as per enclosed drawing.

12. TEST :

Each transformer shall be given the following test in accordance with the reference standard.

1. Measurement of insulation resistance
2. Separate source AC withstand voltage test
3. Induced AC voltage test
4. Measurement of winding resistance
5. Measurement of voltage ratio and check of phase displacement
6. Measurement of no-load loss and current
7. Measurement of short – circuit impedance and load loss
8. Temperature rise , if required.

We shall furnish four certified copies of test reports showing all the above tests at our expenses.

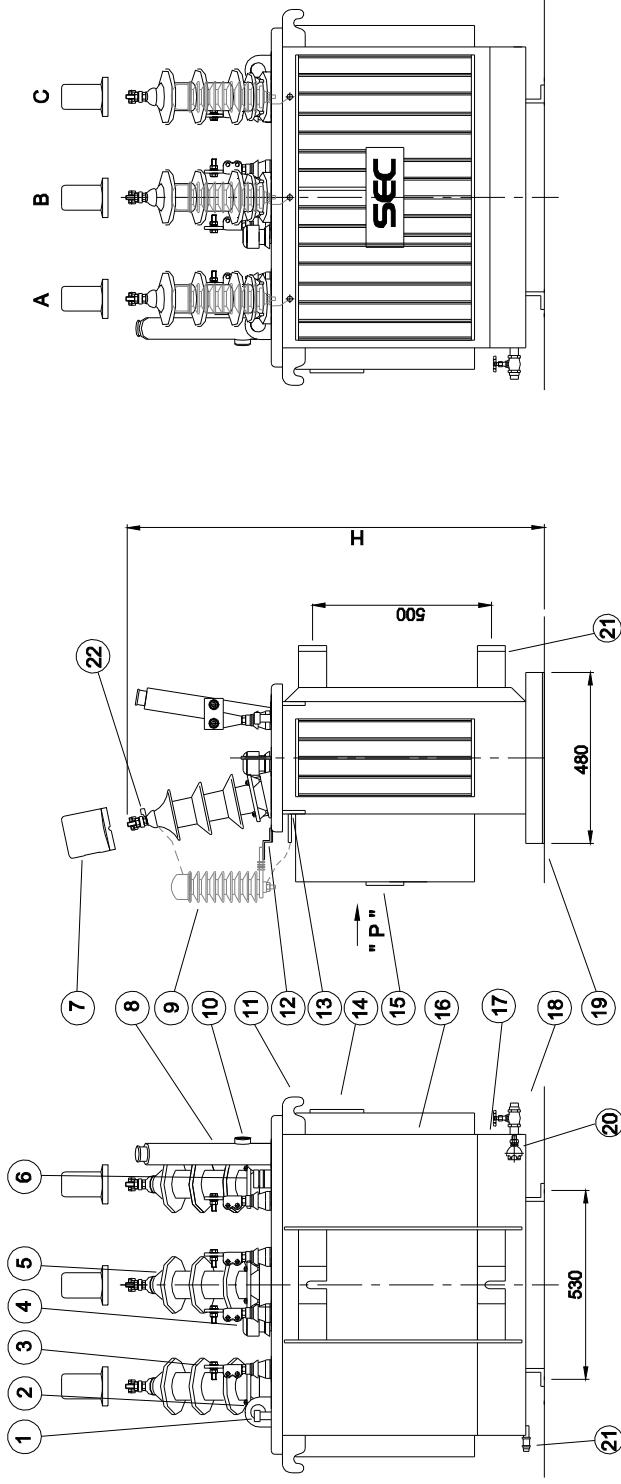

VIEW " P "

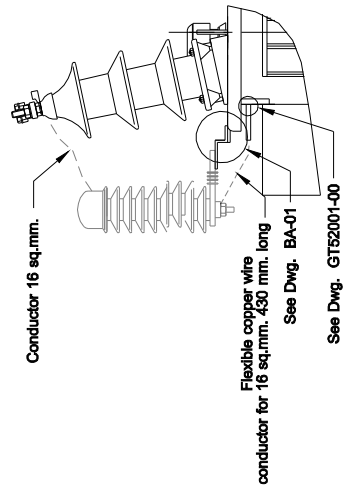
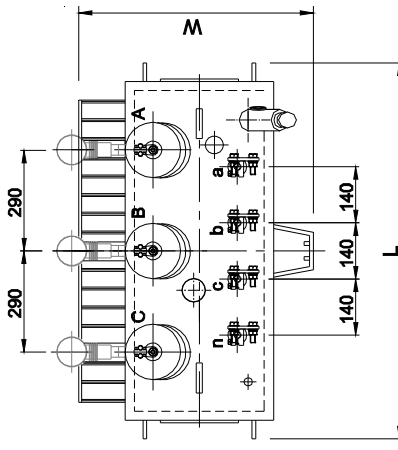

Note : Surge arrester, line lead and ground lead, supplied by PEA

PRELIMINARY DRAWING : This drawing is for estimate only, showing approximate dimensions. It should not be referred to as the final drawing.

LIST OF PART		
No.	PART NAME	Qty
1.	Thermometer pocket	1
2.	Lifting eye for cover	2
3.	LV Bushing with terminal connectors	4
4.	Off load tap changer	1
5.	HV Bushing with terminal connectors	3
6.	Pressure relief device	1
7.	Bird Guard cap	3
8.	Oil filling pipe	1
9.	Surge arrester	3
10.	Liquid level gauge	1
11.	Lifting lugs	4
12.	Bracket for surge arrester	3
13.	Earthing terminal for surge arrester	3
14.	Nameplate with connection diagram	1
15.	Manufacturer plate	1
16.	Corrugated fins	1
17.	Tank	1
18.	Oil drain valve	1
19.	Sub base	2
20.	Earth terminal	1
21.	Supporting lugs	2
22.	Cable lug	3

SEC SAHABHANT ELECTRIC CO.,LTD.

Project :

Title :

OUTLINE DRAWING
OIL IMMersed TRANSFORMER
160 KVA 3Ph 50Hz 22000 - 400/230 V.

Dimension in millimeters		Weight		Oil	
H	L	W	kgs	Litres	
1105	1075	710	690	140	

Signature		Date	
Drawn by	S.Theerasak	12 / 6 / 12	
Checked by	T.Jarin	12 / 6 / 12	
Approved by	T.Jarin	12 / 6 / 12	

Spec. No.	Drawing No.	Rev.
		T0160200308

Requisition No.

