

TX24-5A

Intelligent PSU
Installation and Operation Manual



TANDA UK Technology Copyright ©2016, All right reserved.

Product Safety

To prevent severe injury and loss of life or property, read the instruction carefully before installing the PSU to ensure proper and safe operation of the system.



European Union directive

2012/19/EU (WEEE directive): Products marked with this symbol cannot be disposed of as unsorted municipal waste in the European Union. For proper recycling, return this product to your local supplier upon the purchase of equivalent new equipment, or dispose of it at designated collection points.



For more information please visit the website at www.recyclethis.info

Table of Content

1 Introduction 4

 1.1 Overview 4

 1.2 Feature and Benefits..... 4

 1.3 Technical Specification 4

2 Installation 5

 2.1 Installation Preparation 5

 2.2 Installation and Wiring 5

3 Intelligent PSU 6

 3.1 Preparation..... 6

 3.2 Device Addressing 6

 3.3 Read Configuration 7

 3.4 Working principle and function 7

 3.4.1 Working principle..... 7

 3.4.2 Function introduction 8

 3.5 structure characteristics..... 8

 3.5.1 Outline dimension chart 8

 3.5.2 Structure panel diagram 8

 3.5.3 Panel display and description: 9

 3.5.4 Internal structure diagram 9

 3.5.5 Internal wiring diagram..... 10

4 General Maintenance 10

5 Troubleshooting Guide 11

6 Matters needing attention 11

Appendix 1 11

 Limitation of Intelligent PSU..... 11

1 Introduction

1.1 Overview

TX24-5A Intelligent PSU is to solve the problem of power supply and development of field equipment, power output is about 132.5W (DC26.5V/5A) . The main function of the power supply for the conversion of AC220V voltage to DC26.5V, and with the preparation of electric power supply and power charging function, the standby battery provides the output of the DC24V/12Ah in the AC220V to stop the power supply, start to work with the equipment on the spot to play the role of continuation. The power display function is comprehensive, there are output voltage, output current display, the main power fault, Battery power fault / charge fault(battery fault and charge fault share the LED indicate and fault flag), circuit fault indication, and overload, over current, short circuit protection function. TX24-5A Intelligent PSU has the function of bus network, which can be connected with the TX7004 intelligent fire alarm controller of the company, and provides the corresponding linkage / fault information for the alarm controller.

The unit manufactured base on the requirement of EN 54 part 4, European Standard. The unit is aesthetically pleasing with unobtrusive design that will complement modern building designs and its plug-in type assemblies make installation and maintenance more convenient to the installer. The unit is compatible to the TX7004 Analogue Intelligent Fire Alarm Control Panel, produced by single manufacture T&A, to avoid addressable communication compatibility problem.

1.2 Feature and Benefits

- EN54-4 Compliance
- Built-in MCU processor and digital addressing
- 24VDC/2A fault Output relay
- LED status indicator
- Intelligent charging management
- Aesthetically pleasing design

1.3 Technical Specification

- Compliance EN 54-4: 1997+A1: 2002+A2: 2006
- Input Voltage Loop Power:24VDC [16V to 28V]
Main Power: AC [100V to 240V]
Battery: DC24V/12Ah Sealed lead acid battery (internal)
- Capacity Rated capacity: DC26.5V、 5A(Main power supply)
Maximum capacity: DC26.5V、 5.5A(Main power supply)
- Protocol/Addressing T&A, Value range from 1 to 254
- Dimension / LWH 450 mm x 380 mm x135 mm
- Operating Temperature -5°C to +40°C
- Humidity 0 to 95% Relative Humidity, Non condensing

2 Installation

2.1 Installation Preparation

This Intelligent PSU must be installed, commissioned and maintained by a qualified or factory trained service personnel. The installation must be installed in compliance with all local codes having a jurisdiction in your area or BS 5839 Part 1 and EN54.

2.2 Installation and Wiring

1. In the walls of the corresponding installation position a fixing hole two with a diameter of 12 mm, two holes center distance is 280mm.
2. Using M10 expansion screws through the power installation of the hanging hole, the power will be firmly fixed in the mounting hole in the wall.
3. It will need to access the wire through the hole on the back side or knock off power supply cover, in accordance with the following descriptions of terminal connection (Figure 1).

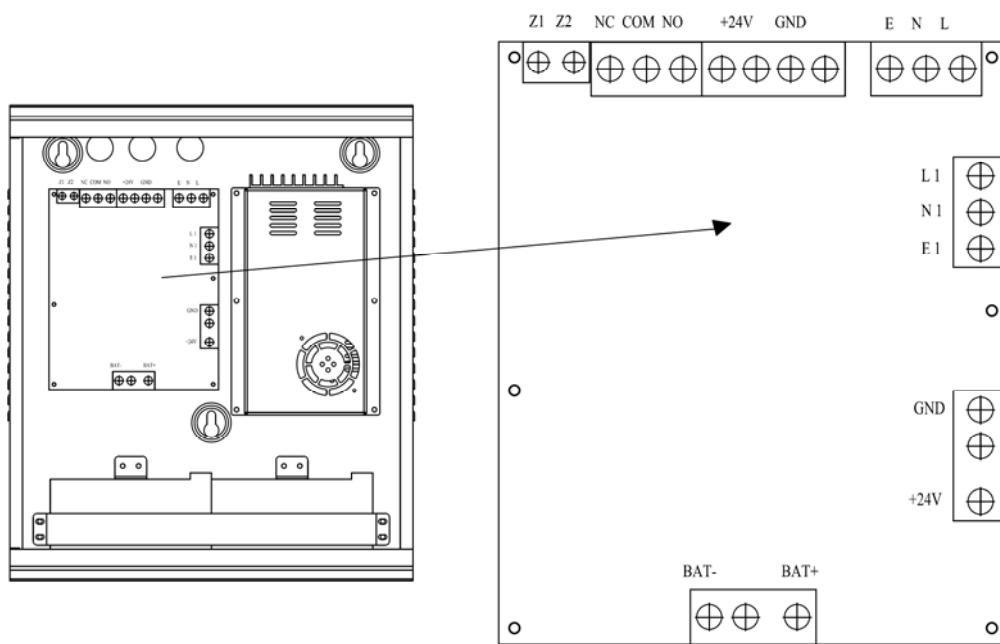

Figure 1: Schematic diagram of external terminals

Terminal description:

Z1、 Z2: Bus input and output terminal.

L、 N、 E: Main electric AC 220V input terminal. (E for chassis ground terminal)

L1、 N1、 E1: AC 220V output terminal. (E for chassis ground terminal)

+24V: 24V Power input.

BAT-、 BAT+: Battery input terminal.

+24V: 24V Output terminal.

NC、 COM、 NO: Fault relay out. Normally open(COM connect NO), when fault,relay closed(COM

connect NC).

4. Check whether the installation is firm, check the wiring is correct.
5. Installation schematic diagram shown in Figure 2.

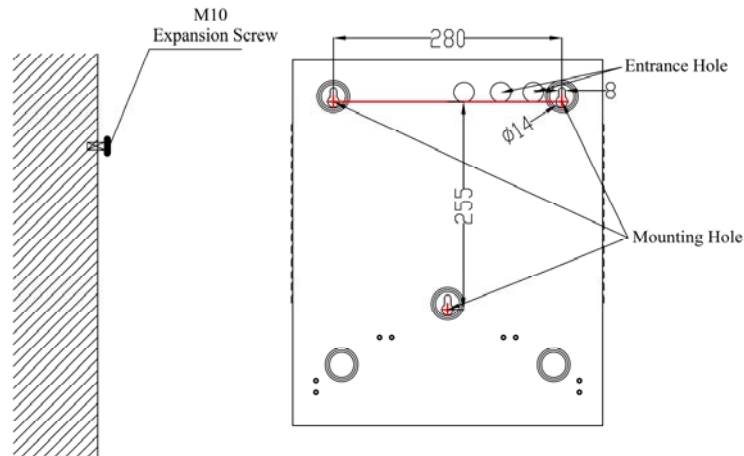

Figure 2: Schematic diagram of power supply installation

3 Intelligent PSU

3.1 Preparation

The TX7930 handheld programmer is used to configure interface module soft address and parameter. This tool is not included, must be purchased separately. The programmer is packed with twin 1.5V AA battery and cable, ready for usage once received.

It is mandatory for the commissioning personnel to have programmer tool enable to adjust the module conferring to the site situation and environmental requirements.

Program a unique address number for each device according to the project layout before placing from the terminal Base.

Warning: Disconnect the loop connection whilst connecting to the handheld programmer.

3.2 Device Addressing

1. Connect the programming cable to Z1 and Z2 terminals (tx24-10A_gl PCB). Press **"Power"** to switch on the unit.
2. Switch-on the programmer, then press button **"Write"** or number **"2"** to enter Write Address mode (Figure 3).
3. Input the desired device address value from 1 to 254, and then press **"Write"** to save the new address (Figure 4).

Note: If display **"Success"**, means the entered address is confirmed. If display **"Fail"**, means failure to program the address (Figure 5).

4. Press **"Exit"** key to go back Main Menu. Press **"Power"** key to switch-off the programmer.

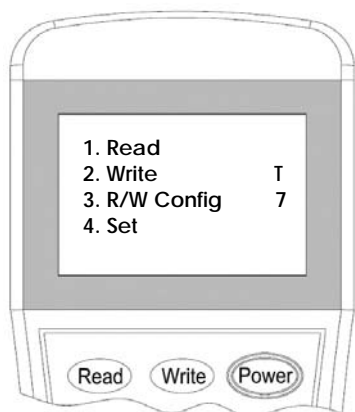

Figure 3



Figure 4



Figure 5

3.3 Read Configuration

1. Attach the programming cable Z1 and Z2 terminals (tx24-10A_gl PCB). Press **"Power"** to switch on the unit.
2. Switch-on the programmer, then press button **"Read"** or **"1"** to enter to Read mode (Figure 6). The programmer will display the configuration after few seconds. (Figure 7).

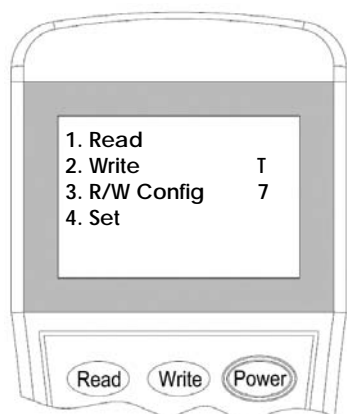

Figure 6

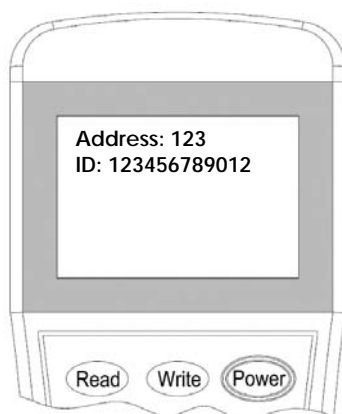

Figure 7

Read Description

Address: Unique number assigned

ID: Device serial number

3. Press **"Exit"** key to go back Main Menu. Press **"Power"** key to switch off the programmer.

3.4 Working principle and function

3.4.1 Working principle

A、 Current output and protection

The AC-DC module will provide power supply voltage to the control panel of 220V electric conversion into DC24V, power management MCU output signal on the relay after the start of the DC24V output control board is connected with the charging circuit, charging power on preparation.

B、 Battery management

1. Battery charging: When the main electric voltage is normal and the battery is connected to the battery. According to the preparation of electric voltage, automatic switching high current charging, trickle charge, float charge mode etc

2. Over discharge protection: In order to prevent excessive discharge of the battery, when the battery voltage is lower than the battery protection voltage (DC21V), the power output is cut off.
3. Main power and Battery power switch: Without electricity, automatically change the battery power supply, when the main power recovery, automatic switching back to the main power supply and charging the battery

3.4.2 Function introduction

A、 Digital tube dynamic display output power supply, output current; LED indicator power running status, include Normal operation, the main electrical fault, power failure, line fault; buzzer sound indicator is in the power failure state

B、 The power supply can alarm the main power, the power supply and the circuit fault. When the input of the main voltage is less than 100V, the main power failure; when the power supply voltage is less than 21V, the power failure; when the output short circuit, over current or fuse, the line fault.

3.5 structure characteristics

3.5.1 Outline dimension chart

Intelligent PSU Outline dimension chart, As shown in Figure 8:

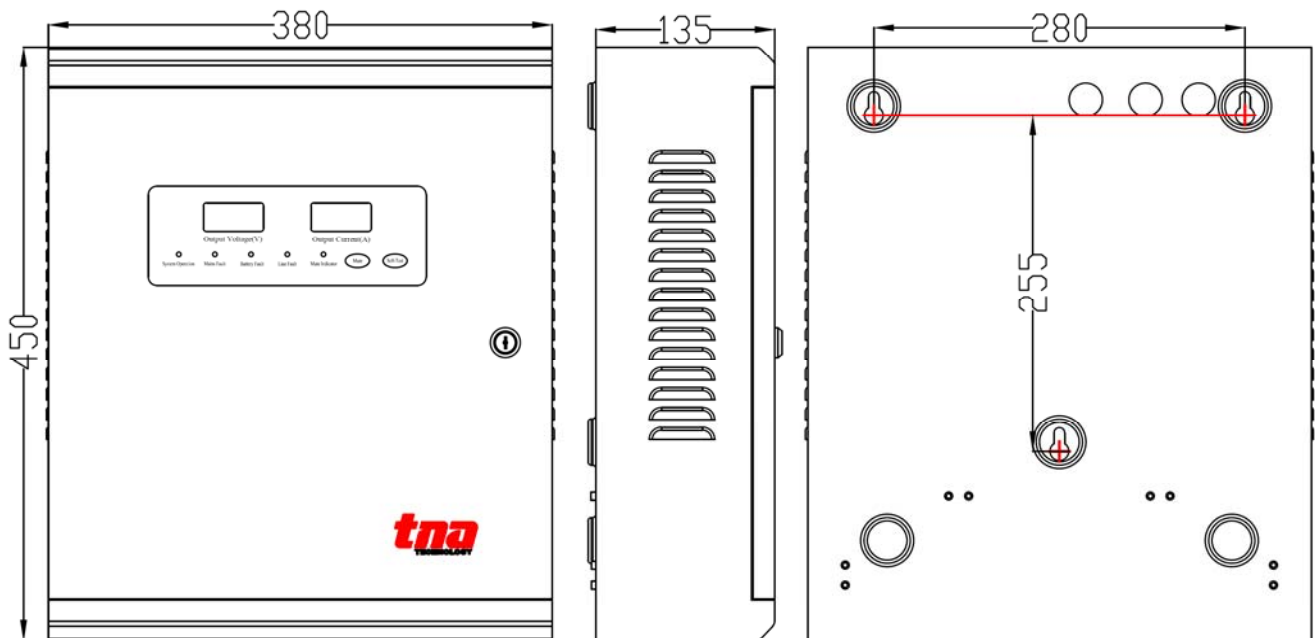

Figure 8: Intelligent PSU figure size

3.5.2 Structure panel diagram

Intelligent PSU Structure panel diagram, As shown in Figure 9:

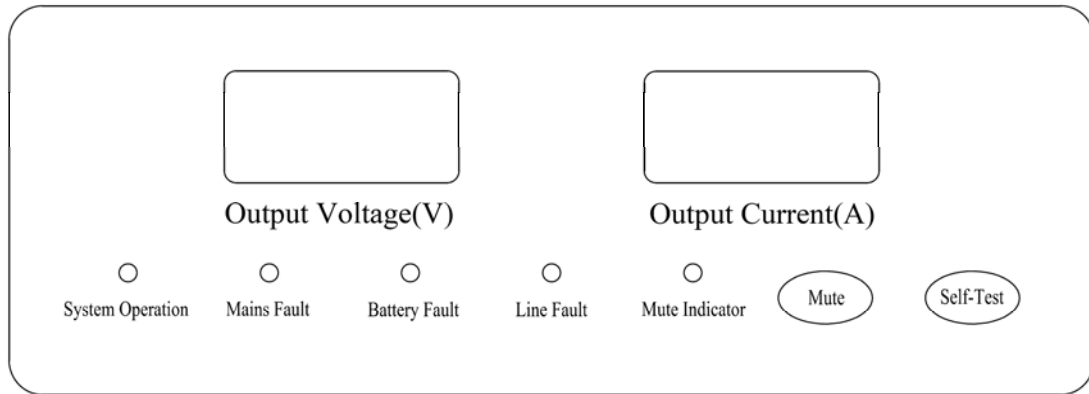

Figure 9: Schematic diagram of panel structure

3.5.3 Panel display and description:

1. Mute key: Press the button when the normal work no response. When there is a fault, buzzer, press this button to mute.
2. Self-Test key: After pressing the display part and the sound part to check.
3. System Operation: Green, when system run normally, illuminated it.
4. Mains fault: Yellow, When illuminated it indicate that a FAULT has been detected in the Mains power .
5. Battery fault: Yellow, When illuminated it indicate that a FAULT has been detected in the battery power.
6. Line fault: Yellow, when Output short circuit, over current, under voltage, illuminated it .
7. Mute indicator: red, when there is a fault and press the mute button, illuminated it.
8. Digital tube voltage display: Normal display output voltage.
9. Digital tube current display: Normal display output current value.

3.5.4 Internal structure diagram

Internal structure diagram, As shown in Figure 10:

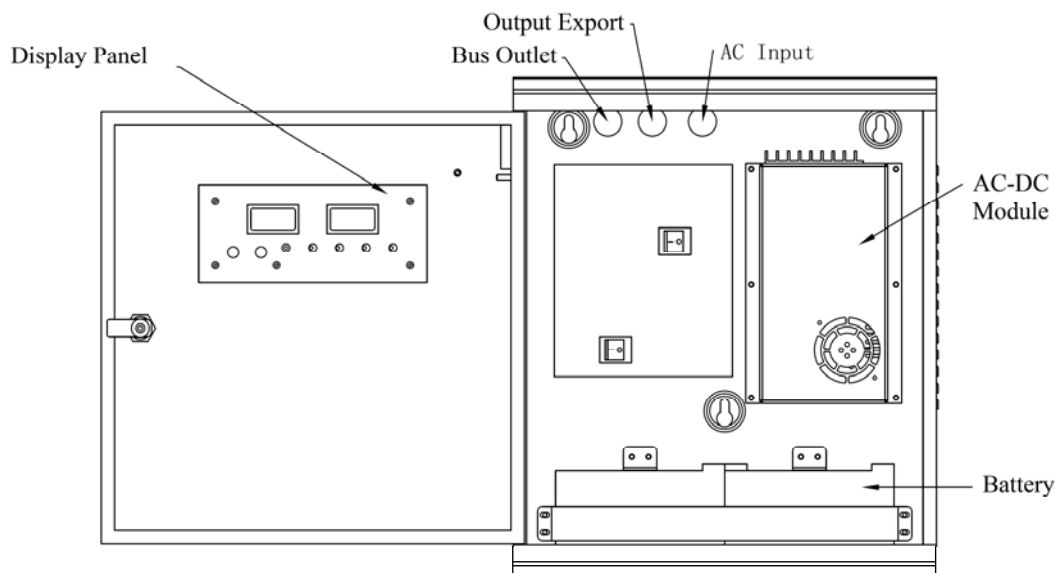

Figure 10: schematic diagram of internal structure

3.5.5 Internal wiring diagram

Internal wiring diagram, As shown in Figure 11:

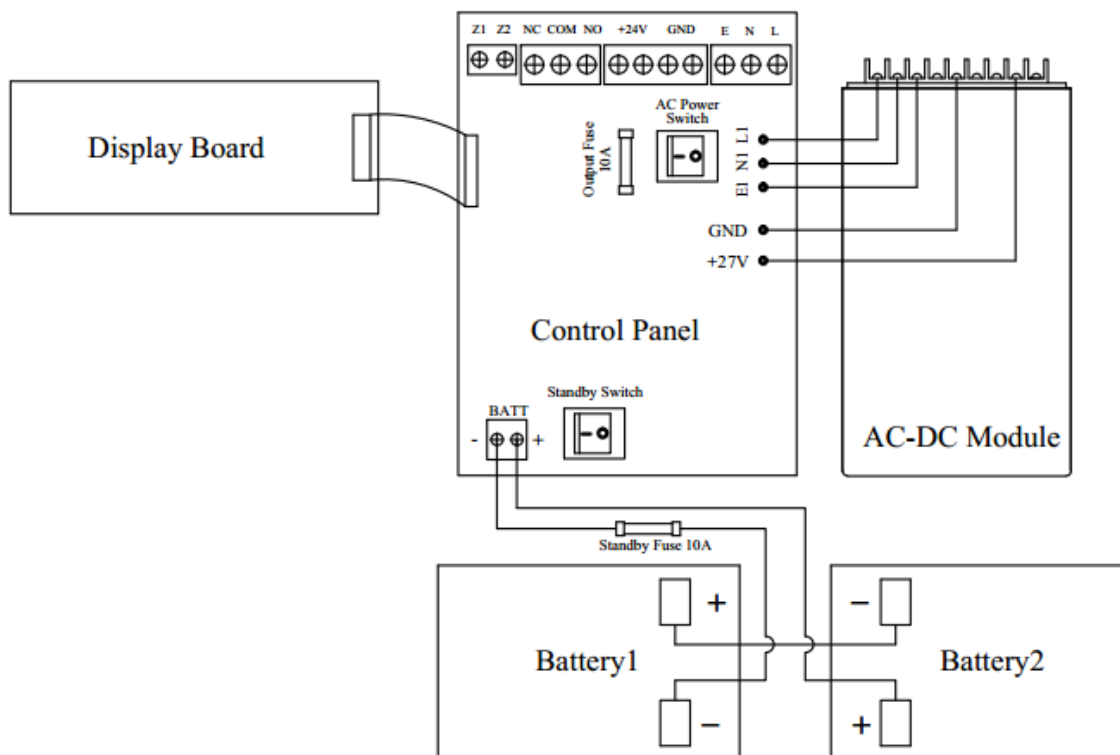

Figure 11: Internal wiring diagram

4 General Maintenance

1. Inform the suitable personnel before conducting the maintenance.
2. Disable the Intelligent PSU on the control panel to prevent false alarm.
3. Do not attempt to repair the circuitry of the Intelligent PSU, it may affect the operation to respond to a fire condition and will void the manufacturer's warranty.
4. Notify again proper personnel after conducting the maintenance and make sure to enable the interface module and confirm if up and running.
5. Perform the maintenance on semi-annually or depending on the site conditions.
6. Main power voltage 220V exists, reported the main power fault, check the internal power supply module and control board connection line is loose.
7. Power up, the output fuse fusing, please check the output circuit is short circuit or reverse connection.
8. Normal output, no display, check between the display board and the control board is good contact wire.
9. Battery voltage is higher than 21V, reported the electrical failure, please check the electrical fuse is good, whether the battery has a reverse.
10. The main power, the battery is normal, no output, reported line fault, check the output fuse is good or re - on the main, electrical.

5 Troubleshooting Guide

What you notice	What it means	What to do
Address not enrolling	The wiring is loose The address is duplicate	Conduct maintenance Re-Commission the device
Unable to commission	The damage the electronic circuit	Replace the device

6 Matters needing attention

1. Before starting the line must be checked without problems, such as short circuit, open circuit, wrong connection, etc.
2. This machine needs to be maintained and maintained by professional training personnel.
3. Our company is responsible for the maintenance of products, please contact our technical service center and found problems in a timely manner, the user will not be allowed to open repair, otherwise the consequences.

Appendix 1

Limitation of Intelligent PSU

The Intelligent PSU cannot last forever. In order to keep the Intelligent PSU working in good condition, please maintain the equipment continuously according to recommendations from manufacturers and relative nation codes and laws. Take specific maintenance measures on the basis of different environments.

These Intelligent PSU contains electronic parts. Even though it is made to last for a long period of time, any of these parts could fail at any time. Therefore, test your Intelligent PSU at least every half-year according to national codes or laws. Any Intelligent PSU, fire alarm devices or any other components of the system must be repaired and/or replaced immediately as they fail.