

**MOTOR SPECIFICATION SHEET**

MODEL : SF-QRGC 10HP 4P RATIO 1:43 (HT)

USED FOR : GEAR MOTOR

DESCRIPTION	DETAIL		
PHASE	3		
MODEL NAME	SF-QRGC		
RATED OUTPUT, HP (kW)	10 (7.5)		
POLE	4		
CODE	MEATH CODE : 1G1043-100H6175QR1		
OUTLINE DRAWING NO.	ONM24O329-A		
RATED VOLTAGE (V)	380	415	
RATED FREQUENCY (Hz)	50	50	
RATED CURRENT (A)	15.4	14.7	
RATED SPEED (min <sup>-1</sup> ) *	34	34	
RATED EFFICIENCY (%)	86.0	86.7	
EFFICIENCY CLASS	IE1		
THERMAL CLASS	155(F)		
RATING	S1 (CONTINUOUS)		
ENCLOSURE CONSTRUCTION	TOTALLY ENCLOSED FAN COOLED		
DEGREES OF PROTECTION	IP55		
METHOD OF COOLING	IC411		
FRAME NO.	132M		
WEIGHT (kg)	162		
STANDARD	IEC 60034-1, IEC 60034-30-1		
INSTALLATION	FOOT MOUNTED		
ROTATION	CW (VIEWED FROM SHAFT END)		
BEARING	LOAD SIDE	: 6308ZZ	
	OPPOSITE SIDE	: 6207ZZ	
BEARING GREASE	UREA GREASE		
CIRCUMSTANCE CONDITION	AMBIENT TEMPERATURE	: -20 ~ +40°C	
	AMBIENT HUMIDITY	: 95%RH OR LESS	
	ABOVE SEA LEVEL	: 1000m OR LESS	
	ENVIRONMENT	: NO BURSTING/EROSIVE GAS OR VAPOR	
COLOR	MUNSELL N1.5 (BLACK)		
TERMINAL BOX	NO. OF LEAD WIRES	: 6	
	SOURCE CONNECTION	: TERMINAL BLOCK	
GEAR RATIO	1:43		
GEAR LUBRICANT	OIL (Must be filled by user.)		
SERVICE FACTOR	1.51		
MATERIAL	FRAME	: STEEL PLATE	
	BRACKET (GEAR SIDE)	: CAST IRON	
	BRACKET (OPP SIDE)	: ALUMINIUM	
	GEAR CASE	: CAST IRON	
	SHAFT (MOTOR)	: STEEL	
	SHAFT (GEAR OUTPUT)	: STEEL	
	STATOR CORE	: ELECTRICAL STEEL	
	WIRE	: ENAMELLED COPPER MAGNET WIRE	
	ROTOR CORE	: ELECTRICAL STEEL	
	CONDUCTOR	: ALUMINIUM	
	TERMINAL BOX	: STEEL PLATE	
	PAINTING	: POLYURETHANE RESIN	
	PRODUCTION COUNTRY	THAILAND	

\* THIS VALUE IS CALCULATED BY " MOTOR RATED SPEED / GEAR RATIO ".

( SPECIFICATION VALUE IS 34 min<sup>-1</sup> .)

Specifications subject to change without notice.

<b>SPECIFICATION SHEET NO.</b>				
SS-M-2861-B				

MODEL SF-QRGC THREE PHASE INDUCTION MOTOR OUTLINE DRAWING

GEAR MOTOR  
 TOTALLY ENCLOSED FAN COOLED  
 DEGREES OF PROTECTION IP55  
 DUST & WATER JET PROOF

CUSTOMER \_\_\_\_\_  
 USER \_\_\_\_\_  
 FOR \_\_\_\_\_  
 CUSTOMER'S ORDER NO. \_\_\_\_\_  
 QUANTITY \_\_\_\_\_  
 MFG. ORDER NO. \_\_\_\_\_

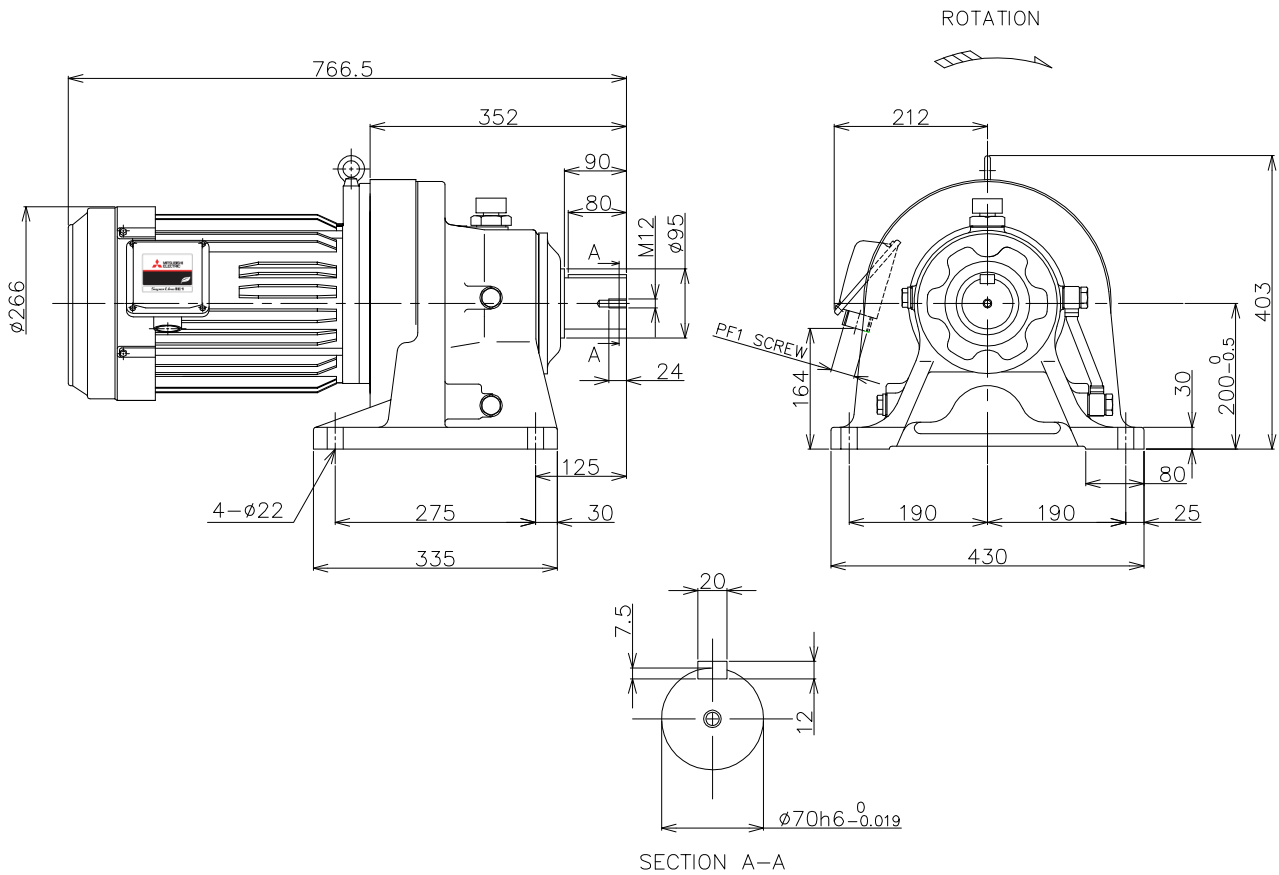

YOUR ORDER	MOTOR FRAME SIZE	RATING	TH. CLASS	AMB. TEMP	BEARINGS		COLOR	DIRECTION OF ROTATION (VIEWED FROM SHAFT END)	NO. OF LEAD WIRES	REMARKS
					LOAD SIDE	OPP. SIDE				
	132M	S1 (CONT.)	155(F)	40°C	6308ZZ	6207ZZ	BLACK (MUNSELL N1.5)	CW	6	

YOUR ORDER	GEAR MODEL	RATIO	SERVICE FACTOR	MOTOR OUTPUT		POLE	VOLT	HERTZ	OUTPUT SPEED (min <sup>-1</sup> )	AMP.	IE CODE-RATED EFF.	TYPE	LUBRICATION TYPE	WEIGHT (kg)
				HP	kW									
	CHHM10-6175-43	1:43	1.51	10	7.5	4	220/380/415	50	34	26.8/15.5/15.0	IE1-86.0%/86.0%/86.2%	LT	OIL <sup>(1)</sup>	162
	CHHM10-6175-43	1:43	1.51	10	7.5	4	380/415	50	34	15.4/14.7	IE1-86.0%/86.7%	HT		

NOTE : (1) PLEASE FILL IN OIL BEFORE FIRST TIME USAGE.(SEE DETAIL IN THE INSTRUCTION MANUAL)

MITSUBISHI ELECTRIC AUTOMATION (THAILAND) CO., LTD.

		OUTLINE DRAWING NO.	REV.
	DIMENSION IN mm. SCALE : NTS	0 N M 2 4 0 3 2 9	A